

USER'S GUIDE
Installation & Operation
Instructions

**SAFSONIC F FIXED ULTRASONIC
TIME OF FLIGHT METER**



Chapter 1.Introduction

1.1 Preface

Welcome to the latest version wall mounted ultrasonic flowmeter which is designed to be installed in a fixed location for long-term flow/heat measurement. Please read this instruction manual thoroughly before installing and operation.

The wall mounted flowmeter is based on transit-time flow measurement principle. It measures flow rate of liquid in a closed pipe by using a pair of clamp-on or wetted ultrasonic transducers. In general, the liquid should be full of pipe, and should contain no or small amount of particles or air bubbles.

The flowmeter is configured as below:

- Transducer:** A pair of ultrasonic transducers clamped on the external surface of a pipe.
- Transmitter:** Transmitter is the main electronic processor. Transducers and transmitter are connected by two double shield high frequency cables.

1.2 New Function Added

Comparing with previous generation wall mounted ultrasonic flowmeter, this version has new functions added as below:

- 1) MODBUS, M-BUS and FUJI extending communication protocol by RS485 port
- 2) 4 thermal energy units optional and applied to the standardization of EU.
- 3) 1G-8G SD data logger available
- 4) Simulation Run Status (For details, please refer to chapter. How to use Simulation Run Status)
- 5) Self-powered 4-20mA output

1.3 Operation Principle

The ultrasonic flowmeter utilizes the well-known transit-time measurement principle, plus our proprietary signal processing and ultrasonic transceiving technologies.

As shown in Figure 1,a pair of ultrasonic transducers are mounted on the pipe of upstream and downstream respectively. Each transducer functions as both ultrasonic transmitter and receiver. The main unit operates by alternately transmitting and receiving a coded burst of sound energy between the two transducers. The transit-times in the upstream direction as well as in the downstream direction are measured. The difference of the two transit times is directly and exactly related to the velocity of the liquid in the pipe.

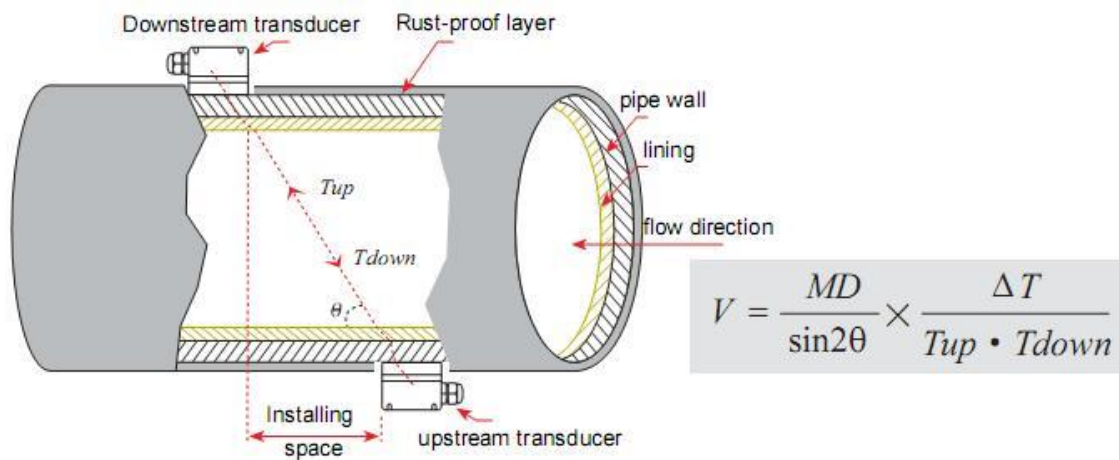

Where

Θ is the angle between the sound path and the flow direction

M is the number of times the sound traverses the flow

D is the pipe diameter

T_{up} is the time for the beam travelling from upstream the transducer to the downstream transducer

T_{down} is the time for the beam travelling from the downstream transducer to the upstream transducer.

$\Delta T = T_{up} - T_{down}$

The flow rate is then computed by combining the velocity information with pipe parameters and a scale factor. The scale factor is normally determined by calibration in factory.

Three types of transducers can be used with transmitter, the clamp-on transducer, the insertion wetted transducer (also called 'hot tap') and the flow-cell inline transducer. All of them don't block the flow, thus, do not generate pressure drop.

1.4 Typical Applications

The flowmeter can be applied in a wide range of pipe flow measurements, Applicable liquids include pure liquids as well as liquid with small quantity of fine particles.

Examples are:

- Water (hot water, chilled water, city water, sea water, waste water, ect.)
- Sewage with small particle content
- Oil (crude oil, lubricating oil, diesel oil, fuel oil, etc.)
- Chemicals (alcohol, acids, etc.)
- Plant effluent
- Beverage, liquid food
- Ultra-pure liquids
- Solvents and other liquids

Applications sorted by industry/process

Water and waste water management;
Water and waste water treatment plants;
Power plants, such as nuclear power plants and hydraulic power plants;
Mining and metallurgy plants;
Petroleum process monitoring and control;
Chemical process monitoring and control;
Pulp and paper process monitoring and control;
Food and beverage processing;
Marine maintenance and operation;
Pipeline leakage detection;
HVAC, hydronic balancing;
Energy supply and production systems;
Flow measurement networking

1.5 Packing list

As different request, the items may vary, but the main should be available as below:

- Transmitter 1 unit
- Transducer 1 set (2ea)
- Transducers cable

1.6 Optional parts

S1 clamp-on transducers for pipe size(1/2"-4")
M1 clamp-on transducers for pipe size(2"-28")
L1 clamp-on transducers for pipe size(11"-240")
S1H clamp-on high temperature transducers for pipe size(1/2"-4")
M1 H clamp-on high temperature transducers for pipe size(2"-28")
Insertion Wetted transducers (hop-tap)
Hot-tap installing tools for insertion transducers
Flow-cell transducer
Shielded transducers cable 2×5 meters
Ultrasonic thickness meter (Test pipe wall thickness for improve accuracy)

1.7 Product Identification

Each set of flowmeter has a unique identification number or ESN (electronic serial number) written into system software that can only be modified with a special tool by the manufacturer. In case of any hardware failure, please provide this number which is located on menu window M61 when contacting the manufacture.

1.8 Specifications

TRANSMITTER	
Accuracy	$\pm 1\%$ of reading, plus $\pm 0.006\text{m/s}(\pm 0.02\text{ft/s})$ in velocity
Repeatability	Better than 0.2%
Velocity range	$\pm 0.03 \sim \pm 105\text{ft/s}(\pm 0.01 \sim \pm 30\text{m/s})$, bi-directional
Measurement period	0.5S
Keypad	4×4 tactile-feedback membrane keypad
Display	LCD with backlight, 2×20 letters
Units	English(U.S.) or metric
Outputs	Analog output: 4-20mA or 0-20mA current output. Impedance 0-1K Ω . Accuracy 0.1%
	Isolated OCT output: for frequency output (0~9,999Hz), alarm driver, or totalizer pulse output, ON/OFF control, etc.
	Relay output 1A@125VAC or 2A@30VDC. For ON/OFF control, alarm driver, totalizer output, etc.
	Sound alarm
Inputs	RTD interface (optional): two temperature channels that can accommodate two PT100 3-wire temperature sensors for thermal energy measurement.
	Analog input: one channel of 4-20mA input. Can be used for temperature, pressure or liquid level sensor
Data Logger	Optional SD data logger from 1G~8G.
Recording	Automatically record the following information: <ul style="list-style-type: none"> •The positive/negative/net flow/heater totalizer data of the last 512days/128monts/10years •The power-on time and corresponding flow rate of the last 30 power on and off events. Allow manual or automatic flow loss compensation.
Communication Interface	Isolated RS-485 with power surge protection. Support the MODBUS protocol. M-BUS and FUJI's extending flowmeter protocol.
Other function	Capable of offline compensation for flow totalizer, automatic/manual selectable. Self-diagnosis
Enclosure	Die-cast aluminum enclosure. Protection Class: IP65.(NEMA 4X). Weather-resisitant. Size: 9.88"×7.56"×3.15"(251×192×80mm)

Weight	2.5kgs
Power supply	85-264VAC/8-36VDC
Temperature	-10°C~70°C
Humidity	85%RH

TRANSDUCER & CABLE

Clamp-on type	Standard S1 for 1”~4”(DN25-DN100mm) Standard M1 for 2”~28”(DN50-DN700mm) Standard L1 for 11”~240”(DN300-DN6000mm) High temperature S1H for 1”~4”(DN25-DN100mm) High temperature M1H for 2”~28”(DN50-DN700mm)
Insertion wetted type	For 3”~240”(DN80-DN6000mm)
Flow-cell inline type	For DN15-DN1000mm
Protection Class	Transducers: IP68
Transducer temperature	Standard clamp-on type: 0°C~70°C High temperature clamp-on type: 0°C~150°C Insertion wetted type: 0°C~150°C Flow-cell inline type: 0°C~150°C
Transducer cable	Shielded transducers. Standard length 15’(5m).Can be extended to 1640’(500m).Contact the manufacture for longer cable requirement. Cable should not be laid in parallel with high-voltage power lines, neither should it be close to strong interference source such as power transformers.

LIQUIDS

Liquid Types	Virtually all commonly used clean liquids. Liquids with small quantity of tiny particles may also be applicable.Particle size should be less than 100um, particle concentration less than 20,000ppm or<2%.Liquid should contain no or very minor air bubbles.
Liquid Temperature	-40°C~155°C depending on transducer type

Pipe

Pipe size	DN25-DN6,000mm(0.5”~240”)
Pipe material	All metals, most plastics, fiber glass, etc. Allow pipe liner

Chapter 2. Installing and Measurement

2.1. Unpacking

Please unpacking the shipping box and check the parts and documents against the packing slip. If there is something missing, the device is damaged or something is abnormal, please contact us immediately and do not proceed with the installation.

WARNING!

The flowmeter can be used to measure flow of many liquids. Some of the liquids may be hazardous. It is important that user comply with local safety codes and regulations in installing and using electronic devices in the area.

2.2. Installation Considerations

This section provides guidelines for installing the wall mounted transmitter and transducers.

2.2.1 Mounting Transmitter

The main unit electronics are housed in an IP68 (NEXA4X) weather-resistant and dust-tight enclosure. There, the main unit can be installed indoors and outdoors. Usually, it is mounted in a meter shed or on a location where one can easily access for meter testing and servicing. *See the following figure for detailed dimensions.*

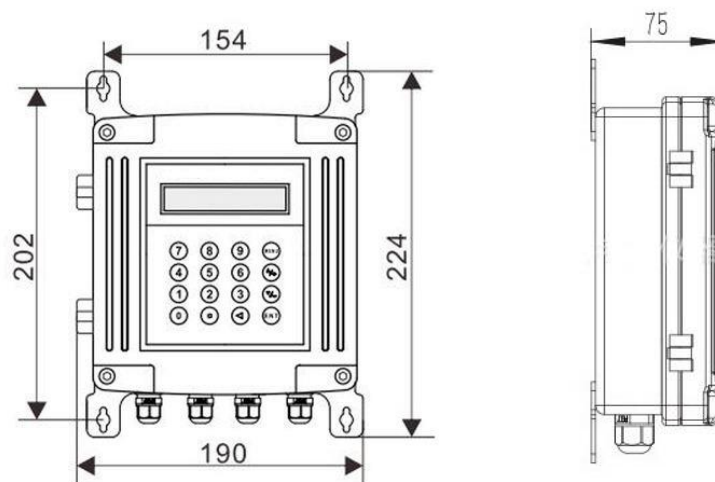

(Dimensions in mm)

2.2.2 Installing Transducers

Firstly, you need to select a proper installation site. For this, one usually needs to consider the accessibility of the location, operating space needed for the installation, safety code compliance, etc. In addition, flow and pipe conditions near the installation site are also very important.

For detailed transducers installation, please refer to transducers installing guide manual separately.

2.2.3 Distance from Transmitter to Transducer

In general, the closer the transducer to the transmitter, the better the signals. All major cable suppliers can supply up to 1640ft (500m) long transducer cable as per specifications.

2.2.4 Transducer Cables

The flowmeter requires twisted shielded cable for the transducers. We recommend to use the cable supplied by the manufacture. If you want to do the transducer cabling by yourself, please consult Flowmetrix SA in advance.

Try not route the transducer cable along with high current AC lines. Avoid strong interference sources. Make sure the cables and cable connections are protected from weather and corrosive conditions.

WARNING!

The transducers may have static charges accumulated during transportation. Before connecting the transducers to the transmitter, please do discharge the transducer in a safe area by shorting the centre conduction of the transducer cable connectors to the main shield of the connector.

2.2.5. Input and output cable

Using standard twisted-pair wiring

2.2.6 Power Supply Wiring

The user normally selects the type of power supply when the order is placed. There are two types of power supply options, 85-264VAC and 24VDC. User must make sure the power supply type of your flowmeter matches the power source to which the flowmeter will be connected.

WARNING!

Be careful about the power supply type of your flowmeter and the power supply wiring! Connecting to a wrong type power source or improper connection of line power could damage the flowmeter. It may also cause hazardous voltage at enclosure, the transducer, flow cell and associated piping.

Open the transmitter enclosure, on the lower left corner(refer to the figure in Appendix 9.1), you should see three terminal blocks which pins are labeled as 11,12 and 13. Normally, pin 13 should be connected to your Earth ground. Make sure your Earth ground is good. Pins 11 and 12 should be connected to Neutral and Line, respectively.

If 24VDC power source is used, its positive lead and negative lead should be connected to pin 21 and 22.

Please refer to the figure in Appendix 8.1 for more wiring information.

2.3.Power Up

The wall mounted flowmeter doesn't have power ON/OFF switch. When it is connected to power, it will start to run automatically.

WARNING!

Before connecting the device to power source, please do a final check to make sure all the wiring are corrected and all the local safety codes are followed.

After the power is turned on, the flowmeter will run a self-diagnostic program, checking first the hardware and then the software integrity. If there is any abnormality, corresponding error messages will be displayed. (Please refer to chapter 7 for more error code explanations.)

After successful internal check, the flowmeter will display menu window 01(short for M01), or the menu window which was active at last power off. It will also start the measurements by using the parameters configured last time by the user or by the initial program.

The flow measurement program always operates in the background of the user interface. This means that the flow measurement will keep running regardless of any user menu window browsing or viewing. Only when the user enters new pipe parameters will the flowmeter change measurement to reflect the new parameters changes.

When the power is turned on or new pipe parameters are entered, the flowmeter will enter into a self-adjusting mode to adjust the gain of the receiving circuits so that signal strength will be within a proper range. By this step, the flow meter finds a the best system gain which matches the pipe material and fluid type. If the self-adapting process is completed successfully, letter 'R' will be displayed.

When the user adjusts the position of the installed transducers, the flow meter will re-adjust the signal gain automatically.

Figure 2.1 keypad

2.4. Keypad operation

The keypad of the flowmeter has 16 keys (Figure 2.1).

Keys [0]~[9] and [.] are number keys.

Key [▼/-] is the going DOWN key when the user wants to go to the lower menu window. It also works as - key when entering numbers.

Key [▲/+] is the going UP key when the user wants to go to the upper menu window. It also works as + key when entering numbers.

Key [◀] is the backspace key when the user wants to go Left or wants to backspace the left character that is located to the left of the cursor.

Key [ENT] is the ENTER key for any input or selections.

Key [MENU] is the key for the direct menu window jump over. Whenever the user wants to proceed to a certain menu window, the user can press this key followed by a 2-digit number.

The [MENU] key is shortened as the 'M' key hereafter when referring to

Key-pressing induced beep sound can be enabled/disabled in menu window M77.



2.5. Menu Windows Entering method

The flowmeter user interface comprises about 100 independent menu windows that are numbered by M00, M01, M02, ..., M99, M+0, M+1, etc.

There are two methods to visit a menu window:

(1) Direct jump in. Simply press the [MENU] key followed by a 2-digit number. For example, if user wants to visit menu window M11 for pipe outer diameter, press the following three keys consecutively,

[MENU] [1][1]

(2) Press the [▼/-] or [▲/+] key. Each time of the [▲/+] key pressing will lead to the lower-numbered menu window. For example, if the current window is on M12, the display will go to window M11 after the [▲/+] key is pressed once.

User doesn't need to remember all the menu windows. Just remember the most commonly used window numbers and the approximate window number of some uncommonly used windows would be sufficient. You can always use [▼/-] or [▲/+] keys to find the right window.

There are three different types of menu windows:

- (1) Menu windows for number entering, e.g., M11 for setting up pipe outer diameter.
- (2) Menu windows for option selection, e.g., M14 for the selection of pipe materials.
- (3) Results display windows, e.g., window M00 for display flow rate, etc.

For number entering windows, the user can directly press the digit key if the user wants to modify the value. For example, if the current window is on M11, and the user wants to enter 219.2345 as the pipe outer diameter, then, the following keys should be pressed: [2][1][9][.][2][3][4][5][ENT].

For option selection windows, user should first press the [ENT] key to get into option selection mode. Then, use [▼/-] or [▲/+], or digit key to select the right option. Consequently, press [ENT] to make the selection.

Generally, the [ENT] key must be pressed to get into the option selection mode for option modifications. If the 'Locked M47 Open' message is indicated on the bottom line of the LCD display, it means that modification operation is locked out. In such cases, the user should go to M48 to have the instrument unlocked before any further modification can be made.

2.6.Quick Guide for parameters setting

In order to get the correct transducer mounting distance(the distance between the front edges of both transducers), verify and set the following parameters;

- (1) Pipe outer diameter (menu M11)
- (2) Pipe wall thickness(menu M12)
Or Pipe inner diameter (menu M13)---only either one.
- (3) Pipe material (menu M14)
- (4) Liner (menu M16)
- (5) Fluid type (menu M20)
- (6) Transducer type (menu M23)
- (7) Transducer mounting method type. (Please refer to transducer installing guide for detailed method selection) (menu M24)

When the parameters above are properly set, the correct transducer mounting distance is calculated and displayed in menu M25

- (8) Solidifying parameters inputting in menu M26. *(For this operation, please refer to window M26 on chapter 3. Window Menu Details.)*

ATTENTION!

It is strongly recommended to solidifying the parameters while making any small changes.

2.7. Installing checkup

After the completion of transducer installation, user should check the following item: the receiving signal strength S, the signal quality Q value, the delta time (travelling time difference between the upstream and the downstream signals), the estimated liquid sound speed, the transit time ratio R, and etc. As such, one can be sure that the flow meter is working properly and the results are reliable and accurate.

2.7.1. Signal Strength

Signal strength S indicates the amplitude of receiving ultrasonic signals by a 3-digit number (000) means there is no signal detected, and (999) refers to the maximum signal strength that can be received. Note that sometimes when no confusion will be introduced, S value is expressed by two digits (00-99) for simplicity.

Although the instrument works well when the signal strength ranges from 60 to 90, stronger signal strength should be pursued, because a stronger signal means a better result. The following methods are recommended to obtain strong signals:

- (1) If the current location is not good enough for a stable and reliable flow reading, or, if the signal strength is lower than 60, relocate to a more favorable location.
- (2) Try to polish the outer surface of the pipe, and apply more couplant to increase the signal strength.
- (3) Tenderly adjust the position of the two transducers, both vertically and horizontally, while checking the signal strength. Stop at the position where the signal strength reaches to maximum. Then, check the transducer spacing to make sure it is the same as or very close to what window M25 shows.
- (4) If the installation method is V-method and the pipe is big, use may need to try Z-method in order to get stronger signal.

2.7.2. Signal Quality

Signal quality is indicated as the Q value in the instrument. A higher Q value would mean a higher signal to Noise Ratio (SNR), and accordingly a higher degree of accuracy able to be achieved. Under normal pipe condition, the Q value is in the range of 60-99, the higher the better.

Causes for a lower Q value could be:

- (1) Interference from other instruments and devices nearby, such as a power frequency transverter which could cause strong interference. Try to relocate the flow meter to a new place where the interference can be reduced.
- (2) Bad sonic coupling between the transducers and the pipe. Try to polish the pipe surface again, clean the surface and apply more couplant, etc.
- (3) The selected pipe section is difficult to conduct the measurement. Relocate to a more favorable pipe line.

2.7.3. Total Transit Time and Delta Time

The total transit time (or traveling time) and the delta time are displayed on menu window M93. They are the primary data for the instrument to calculate the flow rate. Therefore, the measured flow rate will vary as the total transit time and delta time vary. The total transit time should remain stable or vary in a very small range. The delta time normally varies less than 20%. If the variation exceeds 20% in either positive or negative direction, there could be certain kinds of problems with the transducer installation. The user should check the installation for sure.

2.7.4. Transit Time Ratio

Transit-time ratio R is usually used to check whether the transducer installation is good and whether the entered pipe parameters are in consistency with their actual values. If the pipe parameters are correct and the transducers are installed properly, the transit time ratio should be in the range of $100\pm 3\%$. Particularly, when the flow is stand-still, the ratio should be very close to 100%. If this range is exceeded, the user should check:

- 1) If the entered pipe parameters are correct?
- 2) If the actual spacing of transducers is the same as or close to what shown on menu M25?
- 3) If the transducer are installed properly in the right direction?
- 4) If the mounting location is good, if the pipe has changed shape, or if the pipe is too old (i.e., too much corrosion or deposition inside the pipe)?
- 5) If there is any interference source inside of the pipe?
- 6) If there are other aspects which do not meet the measurement requirements as recommended earlier.

3. Menu Window Details

3.1 Menu Windows Arrangement

M00~M09 windows for the display of the flow rate, velocity, date time, totalizers, battery voltage and estimated working hours for the battery.

M10~M29 windows for entering the pipe parameter.

M30~M38 windows for flow rate unit selections and totalizer unit selections.

M40~M49 windows for response time, zeroing, calibration and modification password setup.

M50~M53 windows for the built-in logger

M60-M78 windows for time-keeper initialization, version and ESN information viewing and alarms.

M82 window for viewing date totalizer.

M90~M94 are diagnostic windows for a more accurate measurement.

M97~M99 are not windows but commands for the outputting of display copying and pipe parameter setups.

M+0~M+9 are windows for some additional functions, including a scientific calculator, viewer on records such as total working hours, turn-on and turn-off times, dates and times when the flow meter has been turned on or turned off.

User doesn't need to remember all the menu windows. Just remember the most commonly used window numbers and the approximate window number of some uncommonly used windows would be sufficient.

3.2 Menu Window Details

The major reason that menu windows are still arranged in this way is because software programmer hopes that it can be similar to the previous versions. This can make it easier for the former version users to operate the latest version conveniently.

It is recommended to practice those menu windows on the flowmeter while you are first to use it.

Menu window No.	Function
M00	Display flow rate and NET totalizer If the net totalizer is turned off, the net totalizer value shown on the screen is the value prior to its turn off Select all totalizer unit in menu M31
M01	Display flow rate, velocity
M02	Display date time and POS(positive) totalizer If the positive totalizer is turned off, the positive totalizer value shown on the screen is the value prior to its turn off
M03	Display flow rate and NEG(negative) totalizer If the negative totalizer is turned off, the negative totalizer value shown on the screen is the value prior to its turn off
M04	Display date and time, flow rate. The date and time setting method is found in MENU60
M05	Display energy rate(instantaneous Caloric)and total energy (Caloric)
M06	Display temperatures, inlet T1, outlet T2
M07	Display analog inputs, AI3/AI4, current value and its corresponding temperature or pressure or liquid level value
M08	Display all the detailed error codes Display working condition and system error codes. 'R' stands for normal; others refer to Chapter 5 for details.
M09	Display today's total NET flow
M10	Window for entering the outer perimeter of the pipe If pipe outer diameter is known, skip this menu and go to Menu 11to enter the outer diameter
M11	Window for entering the outer diameter of the pipe. Valid range: 0 to 18000mm. Note: you just need to enter either the outer diameter in M11 or the peripheral in M10

M12	<p>Window for entering pipe wall thickness</p> <p>You may skip the menu and enter inner diameter in M13 instead.</p>
M13	<p>Window for entering the inner diameter of the pipe</p> <p>If pipe outer diameter and wall thickness are enter correctly, the inner diameter will be calculated automatically, thus no need to change anything in the window</p>
M14	<p>Window for selecting pipe material</p> <p>Standard pipe materials (no need to enter material sound speed) include:</p> <p>(0) carbon steel (1) stainless steel (2) cast iron (3) ductile iron (4) copper (5) PVC (6) aluminum (7) asbestos (8) fiberglass (9) other(need to enter material sound speed in M15)</p>
M15	<p>Window for entering the pipe material speed, only for non-standard pipe materials</p>
M16	<p>Window for selecting the liner material, select none for pipes without any liner.</p> <p>Standard liner materials(no need to enter the liner sound speed) include:</p> <p>(1) Tar Epoxy (2) Rubber (3) Mortar (4) Polypropylene (5) Polystyrol (6)Polystyrene (7) Polyester (8) Polyethylene (9) Ebonite (10) Teflon (11) Other (need to enter liner sound speed in M17)</p>
M17	<p>Window for entering the non-standard liner material speed.</p>
M18	<p>Window for entering the liner thickness, if there is a liner</p>
M19	<p>Window for entering the ABS thickness of the inside wall of the pipe</p>
M20	<p>Window for selecting fluid type</p> <p>For standard liquids(no need to enter fluid sound speed) include:</p> <p>(0) Water (1) Sea Water (2) Kerosene (3) Gasoline (4) Fuel oil (5) Crude Oil (6) Propane at -45C (7) Butane at 0C (8)Other liquids(need to enter sound speed in M21 and viscosity in M22) (9) Diesel Oil (10)Caster Oil (11)Peanut Oil (12) #90 Gasoline (13) #93 Gasoline (14) Alcohol (15) Hot water at 125C</p>
M21	<p>Window for entering the sound speed of non- standard liquid, used only when option item 8 'Other' is selected in M20</p>

M22	Window for entering the viscosity of the non-standard liquids, used only when option item 8 'Other' is selected in M20
M23	<p>Window for selecting transducer type, the type can be used as below:</p> <ul style="list-style-type: none"> 3. User Type 5. Insertion Type B(45) (Insertion transducer uses this option) 10. Standard-M1 (high temp. small size also uses this option) 11. Standard-S1 (high temp. medium size also uses this option) 12. Standard-L1 (large size transducer) 13. PI-Type <p>If the user-type-transducer is selected, you need enter additional 4 user-type-wedge parameters that describe the user transducers.</p> <p>If the PI-type transducer is selected, you need enter additional 4 PI-type transducer parameters that describe the PI-type transducers</p>
M24	<p>Window for selecting the transducer mounting methods</p> <p>Four methods can be selected:</p> <p>(0) V-method (1) Z-method (2) N-method (3) W-method</p>
M25	Display the transducer mounting spacing or distance
M26	<p>(1) A switch for the parameters in flash memory will be loaded when power is turned on. The default option is that the parameters will be loaded. If this switch is not turned on, the system will try to use the parameters in the system RAM, if these parameters are ok, otherwise the system will load the parameters in flash memory</p> <p>(2) Function to store the current parameters into the flash memory, so that these parameters will be solidified and will be loaded as the default parameters every time when power is turned on.</p> <p>All setup parameters data are stored in the RAM memory temporally. Users need to solidify the parameters, when setup are been finished, that is to store the parameter to the internal flash memory. Go to Menu 26, select the option that says 'make default paras' then pressing the ENT key will start the progress of storing. If the current parameters are different with that in the flash memory, the system will store your current parameters into the flash memory and then boot again. By doing so, the parameters will always get lost, even when both the power supply and the backup battery are removed.</p>
M27	<p>Entry to store to or restore from the internal Flash memory, as many as 9 different pipe parameter configurations</p> <p>To save or load the current setup parameter, use the going up or going down keys to change the address number, press 'ENT' key, and use going down or going up keys to select to save to or load from the memory.</p>
M28	Entry to determine whether or not to hold (or to keep) the last good value when poor signal condition occurs. YES is the default setup.

M29	<p>Entry to setup empty signal threshold. When the signal is less than this threshold, the pipe is regarded as empty pipe, and the flow meter will not totalize flow.</p> <p>This is based on the fact that, for most occasions, when pipe is empty, the transducer would still receive signal, just smaller than normal, As a result, The flow meter would show normal operation, which is not correct.</p> <p>Make sure that the entered value must be less than the normal signal strength.</p> <p>When much noisy signals are received, to make sure the flow meter will not incorrectly totalize flow, there is also a 'Q' threshold should be entered in M.5</p>																								
M30	<p>Window for selecting unit system. The conversion English to Metric or vice versa will not affect the unit for totalizers.</p>																								
M31	<p>Window for selecting flow rate unit system.</p> <p>Flow rate can be in</p> <table border="0"> <tr> <td>0. Cubic meter</td> <td>short for</td> <td>(m³)</td> </tr> <tr> <td>1. Liter</td> <td></td> <td>(l)</td> </tr> <tr> <td>2. USA gallon</td> <td></td> <td>(gal)</td> </tr> <tr> <td>3. Imperial Gallon</td> <td></td> <td>(igl)</td> </tr> <tr> <td>4. Million USA gallon</td> <td></td> <td>(mgl)</td> </tr> <tr> <td>5. Cubic feet</td> <td></td> <td>(cf)</td> </tr> <tr> <td>6. USA liquid barrel</td> <td></td> <td>(bal)</td> </tr> <tr> <td>7. Oil barrel</td> <td></td> <td>(ob)</td> </tr> </table> <p>The flow unit in terms of time can be per day, per hour, per minute or per second. So there are 32 different flow rate units in total for selection.</p>	0. Cubic meter	short for	(m ³)	1. Liter		(l)	2. USA gallon		(gal)	3. Imperial Gallon		(igl)	4. Million USA gallon		(mgl)	5. Cubic feet		(cf)	6. USA liquid barrel		(bal)	7. Oil barrel		(ob)
0. Cubic meter	short for	(m ³)																							
1. Liter		(l)																							
2. USA gallon		(gal)																							
3. Imperial Gallon		(igl)																							
4. Million USA gallon		(mgl)																							
5. Cubic feet		(cf)																							
6. USA liquid barrel		(bal)																							
7. Oil barrel		(ob)																							
M32	<p>Window for selecting the totalizers unit. Available units are the same as those in M31</p>																								
M33	<p>Window for setting the totalizer multiplying factor</p> <p>The multiplying factor ranges from 0.001 to 10000. Factory default is 1</p>																								
M34	<p>Turn on or turn off the NET totalizer</p>																								
M35	<p>Turn on or turn off the POS (positive) totalizer</p>																								
M36	<p>Turn on or turn off the NEG(negative) totalizer</p>																								
M37	<p>(1) Totalizer reset</p> <p>(2) Restore the factory default settings parameters. Press the dot key followed by the backspace key. Attention, It is recommended to make note on the parameters before doing the restoration</p>																								
M38	<p>Manual totalizer used for easier calibration. Press a key to start and press a key to stop the manual totalizer.</p>																								
M39	<p>Interface Language selection.</p> <p>The selection could also be changed automatically by the system, if English LCD display is used as the display device.</p>																								
M40	<p>Flow rate damper for a stable value. The damping parameter ranges form 0 to 999 seconds.</p> <p>0 means there is no damping. Factory default is 10 seconds</p>																								
M41	<p>Low flow rate (or zero flow rate) cut-off to avoid invalid accumulation.</p>																								

M42	Zero calibration/Zero point setup. Make sure the liquid in the pipe is not running while doing the setup.
M43	Clear the zero point value, and restore the solidified zero point value.
M44	Set up a flow bias. Generally this value should be 0.
M45	Flow rate scale factor. The default value is '1'. Keep this value as '1', when no calibration has been made.
M46	Networks address identification number. Any integer can be entered except 13(ODH, carriage return), 10 (OAH, line feeding), 42 (2AH), 38, 65535. Every set of the instrument in a network environment should have a unique IDN. Please refer to the chapter for communication.
M47	System locker to avoid modification of the system parameters. If password is forgotten, you could send a command 'LOCK0' to the serial input to unlock. Or you can write 0 to REGISTER49-50 under MODBUS protocol.
M48	Entry to linearity correcting data inputs. By using of this function, the non-linearity of flow meter will be corrected. Correcting data shall be obtained by careful calibration.
M49	Displays the input contents for the serial port. By checking the displays, you can know if the communication is ok.
M50	Switches for the built-in data logger. There are as many as 22 different items can be chosen. To turn this function, select 'YES' the system will ask for selecting the items. There are 22 items available. Turn on all those items you want to output
M51	Window to setup the time of scheduled output function (data logger, or Thermo-printer). This includes start time, time interval and how many times of output. When a number great than 8000 entered for the times of output, It means the output will be keeping always. The minimum time interval is 1 second and the maximum is 24 hours.
M52	Data logging direction control. (1) If 'Send to RS485' is selected, all the data produced by the data logger will be transmitted out through the RS-232/RS485 interface (2) If 'To the internal serial BUS is selected, the data will be transmitted to the internal serial bus which allows a thermal printer, or a 4-20mA analog output module, to be connected to it.
M53	Display analog inputs, AI5, current value and its corresponding temperature or pressure or liquid level value.
M54	Pulse width setup for the OCT (OCT1) output. The width range is 6--1000 mS

M55	<p>Select analog output (4-20mA current loop, or CL) mode. Available options:</p> <ul style="list-style-type: none"> (0) 4-20mA output mode (setup the output range from 4-20mA) (1) 0-20mA output mode (setup the output range from 4-20mA, This mode can only be used with Version-15 flow meter) (2) Serial port controls 0-20mA (3) 4-20mA corresponding fluid sound speed (4) 20-4-20mA mode (5) 0-4-20mA mode (can only be used with Version-15 flow meter) (6)20-0-20mA mode(can only be used with Version-15 flow meter) (7) 4-20mA corresponding flow velocity (8)4-20mA corresponding heat flow rate
M56	<p>4mA or 0mA output value, Set the value which corresponds to 4mA or 0mA output current (4mA or 0mA is determined by the setting in M55)</p>
M57	<p>20mA output value, Set the value which corresponds to 20mA output current</p>
M58	<p>Current loop verification Check if the current loop is calibrated correctly.</p>
M59	<p>Display the present output current of current loop circuit.</p>
M60	<p>Setup system date and time. Press ENT for modification. Use the dot key to skip the digits that need no modification.</p>
M61	<p>Display Version information and Electronic Serial Number (ESN) that is unique for each flow meter. The users may employ the ESN for instrumentation management</p>
M62	<p>RS-232/RS485 setup. All the devices connected with flow meter should have matched serial configuration. The following parameters can be configured: Baud rate (300 to 19200 bps), parity, data bits (always is 8), stop bits (1).</p>
M63	<p>Select communication protocol. Factory default is 'MODBUS ASCII. this is a mode for MODBUS-ASCII, Meter-BUS, Fuji Extended Ultrasonic flowmeter Protocol If you are going using MODBUS-RTU you should select 'MODBUS_RTU'.</p>
M64	<p>AI3 value range. Used to enter temperature/pressure values that are corresponding to 4mA and 20mA input current. The display values have no unit, so that they can present any physical parameter.</p>
M65	<p>AI4 value range. Used to enter temperature/pressure values that are corresponding to 4mA and 20mA input current.</p>
M66	<p>AI5 value range. Used to enter temperature/pressure values that are corresponding to 4mA and 20mA input current.</p>

M67	<p>Windows to setup the frequency range (lower and upper limit) for the frequency output function. Valid range is 0Hz-9999Hz. Factory default value is 0-1000 Hz.</p> <p>Please remember to order the module if you need frequency output function.</p> <p>For Version-15 flow meter, you need to indicate on your orders that you need the frequency function; Otherwise you will get a flow meter which has no frequency output circuits.</p>																											
M68	<p>Window to setup the minimum flow rate value which corresponds to the lower frequency limit of the frequency output.</p>																											
M69	<p>Windows to setup the maximum flow Rate value that corresponds to the upper frequency limit of the frequency output.</p>																											
M70	<p>LCD display backlight control. The entered value indicates how many seconds the backlight will be on with every key pressing. If the enter value is great than 50000 seconds, It means that the backlight will always keeping on.</p>																											
M71	<p>LCD contrast control. The LCD will become darker or brighter when a value is entered.</p>																											
M72	<p>Working timer. It can be cleared by pressing ENT key, and then select YES.</p>																											
M73	<p>Window to setup the lower limit of flow rate for Alarm#1.</p> <p>When the flow rate is below the set value, Alarm#1 equals 'on'</p>																											
M74	<p>Window to setup the upper limit of flow rate for Alarm#1.</p> <p>When the flow rate is above the set value, Alarm#1 equals 'on'</p> <p>There are two alarms in the flow meter, and every alarm can be pointed to alarm output devices such as the BUZZER or OCT output or RELAY output. For example, if you want the Alarm#1 is to output by the OCT circuit, you need to set M78 at selection item 6.</p>																											
M75	<p>Window to setup the lower limit of flow rate for Alarm#2.</p>																											
M76	<p>Window to setup the upper limit of flow rate for Alarm#2.</p>																											
M77	<p>Buzzer setup.</p> <p>If a proper input source is selected, the buzzer will beep when the trigger event occurs. The available trigger sources are:</p> <table border="0"> <tr> <td>0. No Signal</td> <td>1. Poor Signal</td> <td></td> </tr> <tr> <td>2. Not Ready (No*R)</td> <td>3. Reverse Flow</td> <td>4. AO Over 100%</td> </tr> <tr> <td>5. FO Over 120%</td> <td>6. Alarm #1</td> <td>7. Reverse Alarm #2</td> </tr> <tr> <td>8. Batch Control</td> <td>9. POS Int Pulse</td> <td>10.NEG Int Pulse</td> </tr> <tr> <td>11.NET Int Pulse</td> <td>12.Energy POS Pulse</td> <td>13.Energy NEG Pulse</td> </tr> <tr> <td>14.Energy NET Pulse</td> <td>15.MediaVel=>Thresh</td> <td>16.MediaVelo<Thresh</td> </tr> <tr> <td>17.ON/OFF viaRS232</td> <td>18.Daily Timer (M51)</td> <td>19.Timed alarm #1</td> </tr> <tr> <td>20. Timed alarm #2</td> <td>21.Batch Totalizer Full</td> <td>22. M51 Timer</td> </tr> <tr> <td>23. Batch Totalizer 90%</td> <td>24. Key Stroking ON</td> <td>25.Disable BEEPER</td> </tr> </table> <p>The default: 24 Key Stroking ON</p>	0. No Signal	1. Poor Signal		2. Not Ready (No*R)	3. Reverse Flow	4. AO Over 100%	5. FO Over 120%	6. Alarm #1	7. Reverse Alarm #2	8. Batch Control	9. POS Int Pulse	10.NEG Int Pulse	11.NET Int Pulse	12.Energy POS Pulse	13.Energy NEG Pulse	14.Energy NET Pulse	15.MediaVel=>Thresh	16.MediaVelo<Thresh	17.ON/OFF viaRS232	18.Daily Timer (M51)	19.Timed alarm #1	20. Timed alarm #2	21.Batch Totalizer Full	22. M51 Timer	23. Batch Totalizer 90%	24. Key Stroking ON	25.Disable BEEPER
0. No Signal	1. Poor Signal																											
2. Not Ready (No*R)	3. Reverse Flow	4. AO Over 100%																										
5. FO Over 120%	6. Alarm #1	7. Reverse Alarm #2																										
8. Batch Control	9. POS Int Pulse	10.NEG Int Pulse																										
11.NET Int Pulse	12.Energy POS Pulse	13.Energy NEG Pulse																										
14.Energy NET Pulse	15.MediaVel=>Thresh	16.MediaVelo<Thresh																										
17.ON/OFF viaRS232	18.Daily Timer (M51)	19.Timed alarm #1																										
20. Timed alarm #2	21.Batch Totalizer Full	22. M51 Timer																										
23. Batch Totalizer 90%	24. Key Stroking ON	25.Disable BEEPER																										

<p>M78</p>	<p>OCT (Open Collect Transistor Output)/OCT1 setup</p> <p>By selecting a proper input source, the OCT circuit will close when the trigger event occurs. The available trigger sources are:</p> <table border="0"> <tr> <td>0. No Signal</td> <td>1. Poor Signal</td> <td>2. Not Ready(No*R)</td> </tr> <tr> <td>3. Reverse Flow</td> <td>4. AO Over 100%</td> <td>5. FO Over 120%</td> </tr> <tr> <td>6. Alarm #1</td> <td>7. Reverse Alarm #2</td> <td>8. Batch Control</td> </tr> <tr> <td>9. POS Int Pulse</td> <td>10.NEG Int Pulse</td> <td></td> </tr> <tr> <td>11.NET Int Pulse</td> <td>12.Energy POS Pulse</td> <td>13.Energy NEG Pulse</td> </tr> <tr> <td>14.Energy NET Pulse</td> <td>15.MediaVel=>Thresh</td> <td>16.MediaVelo<Thresh</td> </tr> <tr> <td>17.ON/OFF viaRS232</td> <td>18. Daily Timer (M51)</td> <td>19.Timed alarm #1</td> </tr> <tr> <td>20. Timed alarm #2</td> <td>21.Batch Totalizer Full</td> <td>22. Periodically M51 Timer</td> </tr> <tr> <td>23.Batch Totalizer 90%</td> <td>24. FO Output</td> <td>25. Oct Not Using</td> </tr> </table> <p>The OCT circuit does not source voltage at its output. It must be connected with an external power and pull-up resistant for some occasions.</p> <p>When the OCT circuit is close, it will draw current. The maximum current shall not be over 100mA.</p> <p>Attention: the maximum voltage applied to OCT can not be over 80 volts.</p>	0. No Signal	1. Poor Signal	2. Not Ready(No*R)	3. Reverse Flow	4. AO Over 100%	5. FO Over 120%	6. Alarm #1	7. Reverse Alarm #2	8. Batch Control	9. POS Int Pulse	10.NEG Int Pulse		11.NET Int Pulse	12.Energy POS Pulse	13.Energy NEG Pulse	14.Energy NET Pulse	15.MediaVel=>Thresh	16.MediaVelo<Thresh	17.ON/OFF viaRS232	18. Daily Timer (M51)	19.Timed alarm #1	20. Timed alarm #2	21.Batch Totalizer Full	22. Periodically M51 Timer	23.Batch Totalizer 90%	24. FO Output	25. Oct Not Using
0. No Signal	1. Poor Signal	2. Not Ready(No*R)																										
3. Reverse Flow	4. AO Over 100%	5. FO Over 120%																										
6. Alarm #1	7. Reverse Alarm #2	8. Batch Control																										
9. POS Int Pulse	10.NEG Int Pulse																											
11.NET Int Pulse	12.Energy POS Pulse	13.Energy NEG Pulse																										
14.Energy NET Pulse	15.MediaVel=>Thresh	16.MediaVelo<Thresh																										
17.ON/OFF viaRS232	18. Daily Timer (M51)	19.Timed alarm #1																										
20. Timed alarm #2	21.Batch Totalizer Full	22. Periodically M51 Timer																										
23.Batch Totalizer 90%	24. FO Output	25. Oct Not Using																										
<p>M79</p>	<p>Relay or OCT2 setup</p> <p>By selecting a proper input source, the RELAY will close when the trigger event occurs</p> <p>The available trigger sources are:</p> <table border="0"> <tr> <td>0. No Signal</td> <td>1. Poor Signal</td> <td></td> </tr> <tr> <td>2. Not Ready(No*R)</td> <td>3. Reverse Flow</td> <td>4. AO Over 100%</td> </tr> <tr> <td>5. FO Over 120%</td> <td>6. Alarm #1</td> <td>7. Reverse Alarm #2</td> </tr> <tr> <td>8. Batch Control</td> <td>9. POS Int Pulse</td> <td>10.NEG Int Pulse</td> </tr> <tr> <td>11.NET Int Pulse</td> <td>12.Energy POS Pulse</td> <td>13.Energy NEG Pulse</td> </tr> <tr> <td>14.Energy NET Pulse</td> <td>15.MediaVel=>Thresh</td> <td>16.MediaVelo<Thresh</td> </tr> <tr> <td>17.ON/OFF viaRS232</td> <td>18. Timer (M51 Daily)</td> <td>19.Timed alarm #1</td> </tr> <tr> <td>20. Timed alarm #2</td> <td>21.Batch Totalizer Full</td> <td></td> </tr> <tr> <td>22. Periodically M51 Timer</td> <td>23. Batch Totalizer 90%</td> <td>24.Disable Relay</td> </tr> </table> <p>The RELAY is of SPST(Single pole, single throw) type. It is rated for 110VAC max and have a current rating of 0.5A resistive load.</p> <p>It highly recommended that a salve relay to be utilized whenever a large resistive load or inductive load is to be controlled.</p> <p>Note. In order to make the user interface compatible with the former version7, the name RELAY was used other than OCT2, but in fact it is an OCT output.</p>	0. No Signal	1. Poor Signal		2. Not Ready(No*R)	3. Reverse Flow	4. AO Over 100%	5. FO Over 120%	6. Alarm #1	7. Reverse Alarm #2	8. Batch Control	9. POS Int Pulse	10.NEG Int Pulse	11.NET Int Pulse	12.Energy POS Pulse	13.Energy NEG Pulse	14.Energy NET Pulse	15.MediaVel=>Thresh	16.MediaVelo<Thresh	17.ON/OFF viaRS232	18. Timer (M51 Daily)	19.Timed alarm #1	20. Timed alarm #2	21.Batch Totalizer Full		22. Periodically M51 Timer	23. Batch Totalizer 90%	24.Disable Relay
0. No Signal	1. Poor Signal																											
2. Not Ready(No*R)	3. Reverse Flow	4. AO Over 100%																										
5. FO Over 120%	6. Alarm #1	7. Reverse Alarm #2																										
8. Batch Control	9. POS Int Pulse	10.NEG Int Pulse																										
11.NET Int Pulse	12.Energy POS Pulse	13.Energy NEG Pulse																										
14.Energy NET Pulse	15.MediaVel=>Thresh	16.MediaVelo<Thresh																										
17.ON/OFF viaRS232	18. Timer (M51 Daily)	19.Timed alarm #1																										
20. Timed alarm #2	21.Batch Totalizer Full																											
22. Periodically M51 Timer	23. Batch Totalizer 90%	24.Disable Relay																										

<p>M80</p>	<p>Window for selecting the trig signal for the built-in batch controller. Available trig sources:</p> <ul style="list-style-type: none"> 0. Key input (press ENT key to start the batch controller) 1. Serial port 2. AI3 rising edge (when AI3 receives 2mA or more current) 3. AI3 falling edge (when AI3 stop receiving 2mA or more current) 4. AI4 rising edge (when AI3 receives 2mA or more current) 5. AI4 falling edge (when AI3 stop receiving 2mA or more current) 6. AI5 rising edge (when AI3 receives 2mA or more current) 7. AI5 falling edge (when AI3 stop receiving 2mA or more current) 8.Timer periodically (define the start time and interval time in M51) 9.Timer daily (define the start time and interval time in M51) <p>For the input analog current signal, 0 mA indicates "0", 4mA or more indicates '1'.</p> <p>By selecting item #8, the batch totalizer can be started periodically by the internal timer located at Menu51. When the batch totalizer is full, a signal which indicate the batch is full can be direct to either the OCT or the RELAY terminals to stop the pump or other devices.</p> <p>By selecting item #9, the batch totalizer could act as totalizer witch runs for only a period of the day so that a alarm signal could be produced if the total flow during that time period is over a certain amount of. For example, if you want a alarm signal which stand for the total flow is over 100 cubic meters during the period of every day from 20:00 to 06:00, setups is like</p> <p style="margin-left: 40px;">M51 start time =20:00:00</p> <p style="margin-left: 40px;">M51 interval =10:00:00</p> <p style="margin-left: 40px;">M51 log times =9999 (means always)</p> <p style="margin-left: 40px;">M80 select item #9</p> <p style="margin-left: 40px;">M81 input 100 (Unit is defined in M30,M31,M32)</p>
<p>M81</p>	<p>The built-in batch controller</p> <p>Set the flow batch value(dose)</p> <p>The internal output of the batch controller can be directed either to the OCT or the RELAY output circuits.</p> <p>M81 and M80 should be used together to configure the batch controller.</p> <p>Note: Because the measuring period is 500mS, the flow for every dos should be keeping at 60 seconds long to get a 1% dose accuracy.</p>
<p>M82</p>	<p>View the daily, monthly and yearly flow totalizer and thermal energy totalizer value.</p> <p>The totalizer values and errors for the last 64 days, 32 last 32 months and last 2 years are stored in the RAM memory, To view them, use the 'ENT' and 'UP' 'Down' keys.</p>
<p>M83</p>	<p>Automatic Amending Function for automatic offline compensation.</p> <p>Select 'YES' to enable this function, select 'NO' to disable it.</p> <p>When the function is enabled, The flow meter will estimate the average flow uncounted (or 'lost') during the offline session and add the result to the totalizer.</p>

M84	<p>Set the thermal energy unit:</p> <p>0. GJ 1. KC 2.KWh 3. BTU</p>
M85	<p>Select temperature sources</p> <p>0. from T1,T2 (factory default)</p> <p>1. from AI3,AI4</p>
M86	<p>Select the Specific Heat Value.</p> <p>Factory default is 'GB'. Under this setting, the flow meter will calculate the enthalpy of water based on the international standard.</p> <p>If the fluid is other than water, you should select option '1. Fixed Specific Heat', and enter the specific heat value of the fluid.</p>
M87	<p>Turn on or turn off the Energy totalizer.</p>
M88	<p>Select thermal energy totalizer multiplying factor.</p> <p>Factory default is '1'.</p>
M89	<p>1. Display the temperature difference</p> <p>2. Window for entering the lowest temperature difference.</p>
M8.	<p>Heat meter is on</p> <p>1. Inlet</p> <p>2. Outlet</p> <p>Select the heat meter installation place.</p>
M90	<p>Display signal strengths S (one for upstream and one for downstream), and signal quality Q value.</p> <p>Signal strength is presented by 00.0 to 99.9, the bigger the value, the bigger the signal strength will be, and more reliable readings will be made.</p> <p>Q value is presented by 00 to 99, the bigger the better. It should at least be great than 50 for normal operations.</p>
M91	<p>Displays the Time Ratio between the Measured Total Transit Time and the Calculated time. If the pipe parameters are entered correctly and the transducers are properly installed, the ratio value should be in the range of 100±3%. Otherwise the entered parameters and the transducer installation should be checked.</p>
M92	<p>Displays the estimated fluid sound velocity. If this value has an obvious difference with the actual fluid sound speed, pipe parameters entered and the transducer installation should be checked again.</p>
M93	<p>Displays total transit time and delta time(transit time difference)</p>
M94	<p>Displays the Reynolds number and the pipe factor used by the flow rate measurement program. Pipe factor is calculated based on the ratio of the line-average velocity and the cross-section average velocity.</p>

M95	<p>(1) Display the positive and negative energy totalizers</p> <p>(2) Upon entering this window, the circular display function will be started automatically. The following windows will be displayed one by one, each window will stay for 8 seconds: M95>>M00>>M01>>M02>>M02>>M03>>M04>>M05>>M06>>M07>>M08>>M90>>M91>>M92>> M93>> M94>>M95. This function allows the user to visit all the important information without any manual action.</p> <p>To stop this function, simply press a key. Or switch to a window other than M95.</p>
M96	This is not a window but a command for the thermal printer to advance 5 lines of paper.
M97	<p>This is not a window but a command to print the pipe parameters.</p> <p>By default, the produced data will be directed to the internal serial bus (thermal printer). You can also direct those data to the serial communication port.</p>
M98	<p>This is not a window but a command to print the diagnostic information.</p> <p>By default, the produced data will be directed to the internal serial bus (thermal printer). You can also direct those data to the serial communication port.</p>
M99	<p>This is not a window but a command to copy the current display window. By default, the produced data will be directed to the internal serial bus (thermal printer). You can also direct those data to the serial communication port.</p> <p>By use of the window copying function, you can hardcopy very window displaying manually by switching windows, or you can obtain the window displaying data by communication.</p>
M+0	Browse the 32 recorded instrument power-on and power-off date and time with the flow rate at the time of power on and off
M+1	<p>Displays the total working time of the flow meter.</p> <p>When the backup battery is removed, the total working time will be reset to zero.</p>
M+2	Displays the last power-off date and time
M+3	Displays the last power-off flow rate
M+4	Displays how many times of has been powered on and powered off.
M+5	<p>A scientific calculator for the convenience of field working.</p> <p>All the values are in single accuracy.</p> <p>The calculator can be used while the flow meter is conducting flow measurement.</p> <p>Water density and PT100 temperature can also be found in this function.</p>
M+6	<p>Set fluid sound speed threshold</p> <p>Whenever the estimated sound speed (displayed in M92) exceeds this threshold, an alarms signal will be generated and can transmitted to BUZZER or OCT or RELAY.</p> <p>This function can used to produce an alarm or output when fluid material changes.</p>
M+7	Displays total flow for this month(only for the time past)
M+8	Displays total flow for this year(only for the time past)

M+9	Display the not-working total time in seconds. The total failure timer will also include the time when power off, if the back-up battery is applied.
M.2	Entry to solidify the zero point. Password protected.
M.5	Setup the Q value threshold. If the present Q is below this threshold, flow rate will be set to 0. This function is useful when flow meter is installed in noisy environment or on airy pipes.
M.8	The maximum flow rates for today and this month.
M.9	Serial port tester with CMM command output for very second.
M-0	Entry to hardware adjusting windows only for the manufacturer
M-1	4-20mA output adjustment
M-2	4mA calibration for AI3 input
M-3	20mA calibration for AI3 input
M-4	4mA calibration for AI4 input
M-5	20mA calibration for AI4 input
M-6	4mA calibration for AI5 input
M-7	20mA calibration for AI5 input
M-8	Lower Temperature Zero setup for the PT100
M-9	Higher Temperature Zero setup for the PT100
M-A	Temperature Calibration at 50°C
M-B	Temperature Calibration at 84.5°C

- Note: 1. Windows in **Red** are new to our older version of flow meter
 2. Windows in **blue** are energy related windows
 3. The term totalizer is also called accumulator

Chapter 4 Data Logger/Outputs/Inputs

The chapter mainly introduces the details and operation of data logger/output/input/batch controller and the function of simulation run status.

•Data Logger

- 1) External SD data logger from 1G-8G---Need order.

•Output

- 1) A self-powered 4-20mA output
- 2) A OCT pulse output
- 3) A frequency output(Using OCT channel)
- 4) A relay output
- 5) An isolated RS485 output support MODBUS.
Use RS485-RS232C converter for RS232 port.

•Input

- 1) Temperature/thermal energy input equipped with 3-wire PT100 resistors.
- 2) way analog input for pressure, temperature, level, etc.

•Others

- 1) Function of simulation run status
- 2) Batch controller

Before making the wiring, please refer to the figure in Appendix 8.1.

4.1 External SD Data Logger

The external SD data logger is installed inside enclosure of wall mounted unit, and uses 3.3VDC power from the flowmeter, as it doesn't have an external power supply. For more details, please contact Flowmetrix SA if you have such request.

4.2 4-20mA Analog current output connection/setup

The 4-20mA output of the flowmeter is self-powered way which doesn't require external power to the wire of current loop. Its accuracy is better than 0.1%. It can be configured into different modes, such as 4-20mA mode, 0-20mA mode, etc. Mode selection can be made in menu M55.

Please refer to the figure in Appendix 8.1 for wiring terminals.







Connect to AO+ (Pin23) and AO-(Pin24).

- 1) Select the mode to be 4-20mA in menu M55
- 2) Set flow rate values which correspond to the minimum current (4mA) and the maximum current (20mA). Enter the two values in M56 and M57 separately.





Example A: flow rate range is 0-100m³/h. Just need to enter 0 in M56 and 1000 in M57.







Example B: flow rate range is -1000-0-2000m³/h. If flow direction is not an issue for the application, select 20-4-20mA mode in M55. Then, enter 1000 in M56 and 2000 in M57. If flow direction is an issue, user needs to select 0-4-20mA mode in M55. This means that the current loop will output 0-4mA when flow rate is negative and 4-20mA when flow rate is positive. Enter -1000 in M56 and 2000 in M57.

Users may need to check whether current loop is “calibration” by M58. The detailed operation is given as below:

Firstly, press keys     , then by pressing keys  and  to call out “0mA”, “4mA”, “8mA”, “16mA”, “20mA”, meanwhile, measure the current of current loop with a higher accurate ampere meter. Lastly, calculate the difference between measuring value and display value of flow meters. If the difference is over the allowed range, it is necessary to re-calibrate the output of the current loop.

Users must open the debugging window before re-calibrating the analog output. The opening way is as below:

Press     ,input password “4213068”, then press  again to open. The open is only valid in this time power ON., and it will be automatically OFF when the password is invalid.

Press     into the standard status of 4mA output, and use the ampere meter to measure the output current of current loop, meanwhile, press  and  change the display value of the flowmeter and watch the value of the ampere meter until it displays 4.00 which means the 4mA calibration is finished. At this time, press  again into the standard status of 20mA output, then calibrate it with the same way for 4mA.

M59 is used to check the present current value of current output, and the value will be varied with changing of flow rate.

4.4 Analog Voltage Signal Output

By connecting a 250Ω/0.25W resistor across the two current output terminals AO+ (Pin23) and AO- (Pin24)., the 4-20mA can be transferred to a voltage output of 1-5V.

4.5. Frequency Output

All the series ultrasonic flow meters have Frequency Output functionality. This frequency output signal, which represents the flow rate, is intended to connect to other instruments.

The Frequency Output is totally user-configurable. Usually, four parameters should be configured.

Enter the lower limit of flow rate in window M68 and higher limit of flow rate in window M69.

Enter the frequency maximum and minimum in window M67.

For example, assume that the flow rate varies in a range from 0m³/h to 3000m³/h, and the required output signal frequency should be in a range of 200Hz to 1000Hz. The user should enter 0 in M68 and 3000 in M69, and enter 200 and 1000 in window M67.

Please note that the user needs to select the frequency output option (the 24th option, 'FO output') in window M78. The user must also make the OCT hardware connection to the device which is supposed to use the frequency output signal.

4.6 Totalizer Pulse Output

The flowmeter is able to produce a pulse output every time when it reaches a unit flow of liquid. This pulse could be used by an external pulse counter to accumulate the flow rate.

The totalizer pulse output can only be transmitted through OCT or relay devices. Therefore, it is necessary to configure the OCT or relay. This can be done in menu M78 and M79. Refer to the next chapter for detail on M78 and M79.

For example, assume that we need to output the POS totalizer through the relay in pulse form, and every pulse represents 0.1 cubic meter of liquid flow. The following steps must be performed:

- 1) Select the Cubic Meter(m³) unit in window M32
 - 2) Select the Multiplier factor as '2. ×0.1' in window M33
 - 3) Select the output option '9. POS INT Pulse' in window M77. (INT standards for integrated or totalized)
- Note that the totalizer pulse must be set properly. It should be neither too big, or too small. If it is too large (e.g., long period), the output pulse will be very slow. If it is too small (e.g., short period), the relay may activate too frequently and its lifetime may be shortened. Besides, pulse loss error may occur. It is recommended to be within 1-60 pulse/minute. You can adjust the pulse period by selecting different totalizer multiplier factor in M33.

4.7 How to produce an alarm signal output

There are two types of hardware alarms that are available with this instrument. One is the audible alarm, and the other is the ON/OFF output signal which can drive an alarm. The audible alarm is also called Buzzer. It is generated internally and can be configured in M77. The ON/OFF output signal is generated through the OCT or relay output which is connected to an external alarm circuitry.

The triggering sources of the alarming events for both the Buzzer and the ON/OFF alarm signal could be:

- 1) There is no receiving signal
- 2) The signal received is too weak
- 3) The flow meter is not in normal measurement mode
- 4) The flow direction is changed
- 5) Overflow occurs at the analogue outputs by 120% or more
- 6) Over flow occurs at the frequency output by 120% or more
- 7) The flow rate is out of the specified range, which is configured in windows M73 and M74 for Alarm #1, and in windows M75 and M76 for alarm #2.

Example A: assume we need the Buzzer to start beeping when the flow meter is not ready in normal measurement. Switch to M77, select item '2.Abnormal Measurement State'

Example B: assume we need the Buzzer to start beeping when the flow rate is less than 300m³/h and greater than 2000m³/h. The following setup steps would be recommended:

- 1) Enter flow rate lower limit 300 in M73 for #1 alarm,
- 2) Enter flow rate upper limit 2000 in M74 for #1 alarm,
- 3) Select item '6.Alarm #1' in M79

Example C: assume we need the OCT output to activate when flow rate exceeds 100~500m³/h and the relay output to activate when flow rate exceeds 600~1000m³/h. The following setup steps would be recommended:

- 1) Enter flow rate lower limit 100 in M73
- 2) Enter flow rate upper limit 500 in M74
- 3) Enter flow rate lower limit 600 in M75

- 4) Enter flow rate upper limit 1000 in M76
- 5) Select item '6.Alarm #1' in M78
- 6) Select item '6.Alarm #1' in M79

4.8 OCT output

The OCT output is an ON/OFF type, electrically isolated collector open circuit output. It is user-configurable. You can program it to be an ON/OFF type alarm signal or a totalizer pulse signal.

Notice the Frequency Output shares the same OCT hardware. When used as Frequency Output, the OCT cannot be used for other purpose (neither alarm signal nor totalizer pulse signal).

The OCT has two wiring terminals, terminals 28 and 29. Terminal 28 is positive and terminal 29 is negative. Be careful of the polarity.

There are two options used to wire an external circuit to the OCT output

Option 1

An external DC power supply V_x and an external current limiting resistor R_x are needed to use the OCT.

The OCT can drive a relay, which operate a valve system for instance.

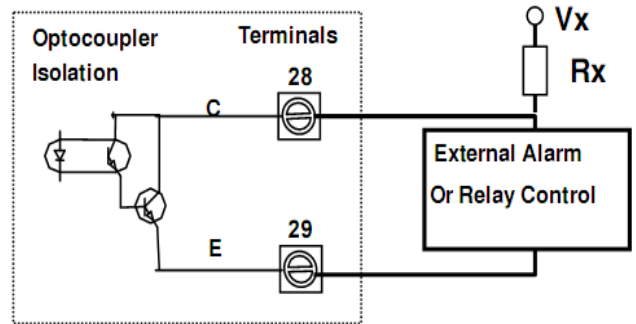

The current flowing through the OCT internal circuit should not exceed 500mA and the pulse width should be short in order to limit power dissipation on the current limiting resistor R_x , when the OCT is closed.

Example

Assuming we have a 24Vdc relay with coil resistance of 1kOhm and 16Vdc coil operating voltage .The ideal circuit would be of V_x 24Vdc and R_x 470 Ohm, In this case the current flowing through the OCT is limited at 51mA and the current through the Relay is 16mA, enough to energize the Relay coil.

Current through OCT

$$I = \frac{V_x}{R_x}$$

$$I = \frac{24}{470}$$

$$I = 51mA$$

Current through Relay

$$I = \frac{V_x}{(R_x + R_{coil})}$$

$$I = \frac{24}{(470 + 1000)}$$

$$I = 16mA$$

Option 2

In this case the relay is connected between the positive terminal of the OCT and the positive end of the DC power supply V_x .

The internal Coil resistance limits the current flowing through the OCT internal circuit

Refer to menu M78 for OCT configuration.

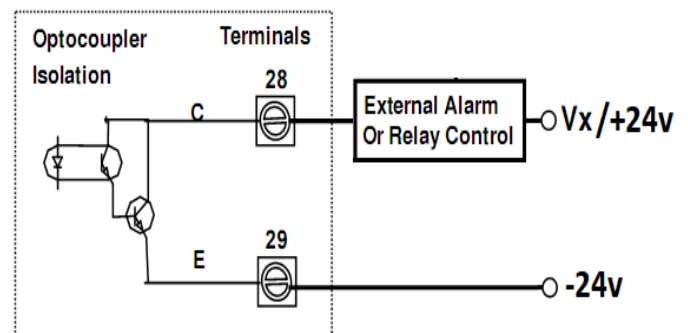

4.9. Relay output

The relay output is a single-pole Single-throw (SPST), normally ON output device. Its load current is 1A at 125VAC or 2A at 30VDC.

The relay output is user-configurable and can be configured as an ON/OFF type alarm signal or a totalizer pulse signal. Its signal is sent to terminals 30 and 31, which can be connected to a remote counter or alarm device (Figure 4). Refer to menu M79 for relay configuration.

4.10. Simulation Run Status

The new version flowmeter has a function of simulation run status. This function can help the flowmeter communication and other function tested without installing transducers. The detailed method is as below:

Input '0' in window M11, the flowmeter will display flow velocity=1.23456m/s (4.0504 ft/s),and display'R'. If request instantaneous flow rate =X, just input '-X' in window M44.

4.11. RS232/RS485 port

The RS485 port is isolated, and has two terminals:RS485+ and RS485-. RS485 port is hardware channel of communication protocol.

For RS232 port, users can use a RS232-RS485 port.

For detailed communication protocol contents, please refer to manual of MODBUS and other protocol separately.

4.12. Analog Input of Pressure and Level

The flowmeter has three analog inputs modules built-into its hardware system, AI3-AI5, which can be connected to analog sensors to measure physical quantities, such as temperature, pressure, etc. By combining the flow rate information, the flowmeter can provide very valuable information for resources management and process control.

The corresponding value of AI3,AI4, AI5 need to be set on M64,M65,M66 separately.

The prior digit corresponds to the analogue value of 4mA, and the latter digit corresponds to the analogue value of 20mA.

Example, assume to input pressure range 0~10kgs from pressure transmitter. The 4-20mA signal of pressure transmitter is connected to GND and AI5, then input '0' to 4mA and '10' to 20mA in window M66.

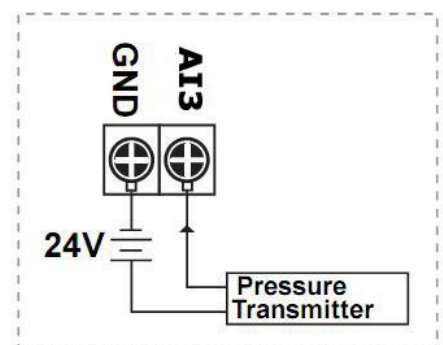

If the current value of pressure transmitter is different from that displayed on window M51, it will need recalibration for the analogue wire.

For detailed calibration information, please contact Flowmetrix SA.

4.13 How to use batch controller

The interval time of batch controller is from 5ms to 500ms.

Please do the following to use the batch controller:

- 1) Go to menu window M80 to select the trig signal.
- 2) Go to menu window M78 (OCT output) or M79 (relay output), select "8 Batch Control".
- 3) Use menu window M81 to set the flow batch value (dose).

The input signal can be set and controlled by keypad or analog input port or MODBUS. The signal is outputted by OCT or Relay.

Chapter 5 Thermal Energy Measurement

5.1 General Introduction

The new version flowmeter has two methods for thermal energy measurement;

- Utilize standard 2-way PT100 resistors. Its temperature range is 0-150°C, and after calibration, the accuracy in the range of 0-150°C is less than 0.1°C.
- Utilize temperature transmitter with 4-20mA output. The temperature analogue signal can be inputted by terminals AI4 and AI5 of the flowmeter. If possible, we recommend PT100 resistors which can have a better performance.

New generation ultrasonic flow meters have two specific heat value methods in system software: one is GB, standard CJ128 specific heat value(factory default),under this setting, the flow meter will calculate the enthalpy of water based on the international standard; the other is 1. Fixed Specific Heat, if the fluid is other than water, users should select option '1. Fixed Specific Heat', and enter the specific heat value of the fluid. If the temperature is over 150°C, also use this method.

Because specific heat of water is different in different temperatures, the measuring results with two methods above are also different. Generally, the result in the first method is smaller than that from the second method.

1) With specific heat value method

While flow transducers installed on water supply pipe, the formulation is as below:

Instantaneous Heater rate $qh=qV \times pS \times (hS-hR)$

While flow transducers installed on water return pipe, the formulation is as below:

Instantaneous Heater rate $qh=qV \times pR \times (hS-hR)$

Here:

- qV:** instantaneous volume flow rate
- pS:** density in water supply temperature
- pR:** density in water return temperature
- hS:** specific heat value in water supply temperature
- hR:** specific heat value in water return temperature

2) With fixed specific heat value method

$qh=qV \times C \times (tS-tR)$

Here:

C: Specific heat value of water, the value can be input in M86

- tS:** temperature of water supply
- tR:** temperature of water return

Heat totalizer: $Q=Qn+qH \times \Delta t$
 $\Delta t=0.5\text{second}$, which means totalizer time is 0.5s.

In window menu M8., users can select installing point: water supply direction or water return direction. The factory default is water supply installing and GB, standard CJ128 specific heat value.

5.2 Wring Connection of PT100 Resistors

TX1 terminal of flow meter is connected to power supply terminal of PT100 RTD in water supply pipe.

T1 terminal of flow meter is connected to signal terminal of PT100 RTD in water supply pipe.

TX2 terminal of flow meter is connected to power supply terminal of PT100 RTD in water return pipe.

T2 terminal of flow meter is connected to signal terminal of PT100 RTD in water return pipe.

Two piece of PT100 resistors are common-ground, and connected to terminal **GND**.

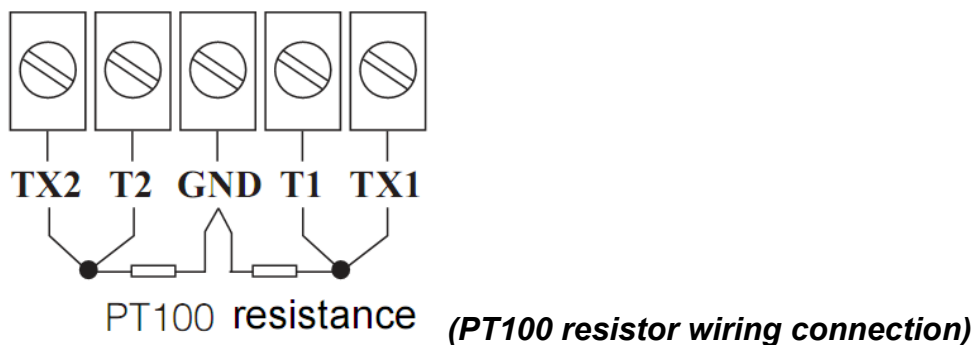

To lengthen the wire of PT100 RTD, please try to use wire with thicker diameter, and also ensure the same specification for 3 wires to connect to the PT100 RTD.

Please kindly note the thermal energy measurement circuit and flow measurement circuit are common-ground.

5.3 Window Menus for Thermal Energy Measurement

Menu window M05: display energy rate (instantaneous Caloric) and total energy (Caloric).

Menu window M06: display the current temperature value of supply T1 and return T2 and their corresponding resistor values.

Menu window M84: the thermal energy unit selection:

0. GJ (factory default) 1. KC 2.KWh 3. BTU

Menu window M85: select temperature sources 0.from T1,T2(factory default)

1. from AI3,AI4

Menu window M86: Select the Specific Heat Value.

Menu window M87: Turn on or turn off the Energy totalizer.

Menu window M88: Select thermal energy totalizer multiplying factor. Factory default is '1'.

Menu window M89: 1. Display the temperature difference
2. Window for entering the lowest temperature difference (temperature cutoff).

Menu window M8.: Select to which pipe the heat meter is installed, the inlet or outlet pipe.

Menu window M95: Display the positive and negative energy totalizers

Menu window M-8,M-9,M-A,M-B: are used to calibrate temperature measurement system.

5.4 Calibrating Sub-system of Temperature Measurement

The accuracy of temperature measurement part is generally 0.5°C if without calibration. Thus, if replace PT100 resistor or replace temperature measurement components, the accuracy will be about 1°C.

In order to gain the accuracy of 0.1°C, it is necessary to calibrate temperature measurement part. It is usually calibrated by using thermostat.

The flow meters use two standard temperature point to calibrate: 50°C and 84.5°C.

Set two thermostats, one is set at 50±0.05°C, and the other is set at 84.5±0.05°C, then follow the steps as below:

- (1) Immerse two pieces of PT100 resistors into 50±0.05°C thermostat
- (2) Enter **MENU** **▼/←** **0**, input hardware debug password 4213068 to open debug window.
- (3) Enter **MENU** **▼/←** **9**, then enter **▼/←** to window menu M-A(M-), the flow meter will display 'Temperature Calibration at 50°C' and T1,T2 current original temperature value.
- (4) After PT100 is fully stable by estimating(about 2 minutes),enter **ENT**. Then enter **•** to continue into M06 for displaying temperature value.
- (5) Immerge the two pieces of PT100 resistors into84.5±0.05°C thermostat
- (6) Enter **MENU** **▼/←** **9**, then enter **▼/←** to window menu M-A(M-), then re-enter **▼/←** to window menu M-B, the flow meter will display ' Temperature Calibration at 84.5°C' and T1,T2 current original temperature value.
- (7) After PT100 is fully stable by estimating (about 2 minutes), enter **ENT**. Then enter **•** to continue into M06 for displaying temperature value.
- (8) Calibration finished, then check the calibration result.

If the flow meter displays similar meaning of wrong calibration temperature, please confirm, on fourth step or seventh step, that means something wrong with calibration temperature or

temperature measurement circuit.

If under the condition without thermostats or on field spot, the ultrasonic flow meters also have a zero setup function of 2-way PT100 resistors, and this function is used to correct the problem for matching error between two PT100 resistors. Lower temperature zero setup for PT100 is in window menu M-8,and higher temperature zero setup for PT100 is in window menu M-9.

While zero point setup, it is better to immerge two PT100 into enough water, and wait for PT100 fully and averagely heated. Then enter to **MENU** **▼/←** **8** or **MENU** **▼/←** **9** to continue. Please note the lower temperature value is not over 40°C,and higher temperature value is at least 55°C.

Zero point setup for temperature initially solves the 'zero point' in PT100. The best way is still to use thermostats for calibration.

5.5 4-20mA Output of Temperature Measurement

●Instantaneous heater rate can be output by 4-20mA

Firstly, select '8.4-20mA corresponding heat flow rate' in window menu M55. Then select 4mA corresponding heater value in M56, and 20mA corresponding heater value in M57.

An application case:

Instantaneous heater rate range is 0-1000GJ/h, the flow meter is connected to a DCS system by 4-20mA output. And request instantaneous heater rate=0,current output value=4mA, and while 1000GJ/h, current output value=20mA. The detailed steps are as below:

- A. Enter M55, then enter **ENT**, use **▼/→** to select 8.4-20mA corresponding heat flow rate
- B. Enter M56, input '0', then enter **ENT**
- C. Enter M57, input '1000', then enter **ENT**

●The temperature measurement value outputted by printer or data recording

- 1). Instantaneous heater rate
- 2) Negative heater totalizer
- 3) Positive heater totalizer
- 4) Net heater totalizer
- 5) T1 temperature value
- 6) T2 temperature value
- 7) Analog input AI3, AI4

The setup window menu is M50, M51 and M52.

For example, request to output instantaneous heater rate, positive heater totalizer, T1 temp. value, the time unit is per second.

The detailed setup is as below:

- A. Enter M50, make the requested option ON
- B. Enter M51, set start time=**.**.**, interval time 00:00:01, print times:8000
- C. Enter M52, select option 'Send to RS485'

For other outputs of heater measurement, they will be the same as that of flow measurement.

6. How To

6.1 How to judge if the instrument works properly

Enter into window M08, if 'R' is displayed on the screen, the instrument is working properly, if other indication character is up, please refer to Chapter 7 for diagnosis details.

6.2 How to judge the liquid flowing direction

- (1) Make sure that the instrument works properly
- (2) Check the flow rate for the indication. If the displayed value is POSITIVE, the direction of the flow will be from the A transducers to the B transducers; if the displayed value is NEGATIVE, the direction will be from the B transducers to the A transducers;

6.3 How to change between units systems

Use menu window M30 for the selection of unit system in English or Metric system.

6.4 How to select a required flow rate unit

Use menu window M31 to select the flow unit first and then the timing unit.

6.5 How to use the totalizer multiplier

Use window M33 to select a proper totalizer. Make sure that the totalizer pulse is appropriately speeded. It should not be too fast and neither too slow. A speed of producing a pulse in several seconds or minutes is preferable.

If the totalizer multiplier is too small, there can be a loss of accumulation pulse because the output device can output only one pulse in a measurement period (500milliseconds)

If the totalizer multiplier is too large, the output pulse will be too fewer for the devices that are connected with the instrument for a quicker response.

6.6 How to open or shut the totalizers

Use M34, M35 and M36 to turn on or turn off the POS, NEG, or NET totalizer respectively.

6.7 How to reset the totalizers

Use M37 to reset the proper totalizer.

6.8 How to restore the flow meter with default setups

Use M37, when the 'selection' message is displayed. Press the dot key first and the message 'Master Erase' will display, then press the backspace key 

The master erase step will erase all the parameters entered by the user and setup the instrument with default values except "instrument factor" and "network identification number" parameter

6.9 How to use the damper

The damper acts as a filter for a stable reading. If '0' is entered in window M40, that means there is no damping. A bigger number brings a more stable effect. But bigger damper numbers will prevent the instrument from acting quickly.

Numbers 0 to 30 are commonly used for the damper value. Default value is 10 seconds.

6.10 How to use the zero-cutoff function

The number displayed in window M41 is called the lower flow rate cut-off value. The flow meter will replace these flow rate values that are absolutely less than the low-cutoff value with '0'. This means the flow meter will avoid any invalid accumulation when the actual flow is below the zero-cutoff value. Generally the default value is 0.03m/s

The low-cutoff value does not affect the flow measurement when the actual flow is absolutely greater than the low-cutoff value.

6.11 How to setup a zero point

There exists a 'Zero Point' with certain installation which means the flow meter will display a non-zero value when the flow is absolutely stopped. In this case, setting a zero point with the function in window M42 will bring a more accurate measurement result.

Make sure that there is no liquid running inside the pipe, and then run the function in window M42 by pressing the **ENT** key.

6.12 How to get a scale factor for calibration

A scale factor is the ratio between the 'actual flow rate' and the indicated value by the flow meter. It can be determined by calibration with standard flow calibration equipment. You may change the scale factor in menu window M45.

The scale factor can be determined by calibration with flow calibration equipment.

6.13 How to use the system locker

The system locker provides a means of preventing inadvertent configuration changes or totalizer resets. When the system is locked, menu window browsing can be done without affecting any change, but any modifications are prohibited.

The system can be locked without a password or with a 1 to 4 digit password. With a no-password locking, directly press the ENT key in M47

If the password is forgotten, please contact the factory.

6.14 How to modify the built-in calendar

No modification on the built-in calendar will be needed in most cases. The calendar runs on insignificant amount of power supply. Modification will be required only in such cases as when the battery is totally consumed, or when the changing of the battery takes a long time.

Press the ENT key under M60 for Modification. Use the dot key to skip over these digits that need no modification.

6.15 How to view the Date Totalizers

Use M82 to view the date totalizers that are comprised of a daily totalizer, a monthly totalizer and a yearly totalizer.

6.16 How to use the Working Timer

Use the working timer to check the time that has passed with a certain kind of operation. For example, use it as a timer to show how long a fully-charged battery will last.

Under M72, press ENT key and then select YES to reset the timer.

6.17 How to use the manual totalizer

Use M38 for the manual totalizer. Press ENT key to start and stop the totalizer.

6.18 How to check System Version Number

Every set of the flowmeter utilizes a unique ESN to identify the meter. The ESN is an 8-digit number that provides the information of version and manufacturing date.

The user can also employ the ESN for instrumentation management.

The ESN and system version number is displayed in window M61.

6.19 How to adjust the LCD display

You may use menu window M70 to setup the LCD display backlight and menu window M71 to adjust contrast it.

6.20 How to use automatic amending function for offline compensation

Use menu window M83 turn on or turn off this function. When the function is enabled, the flow meter will estimate the average flow uncounted (or 'lost') during the offline session and add the result to the totalizer.

This function is not recommended. The user should try to avoid the offline time to keep precision of the measurement result.

6.21 How to enter the parameters of user-type-transducer

If a user-type-transducer is selected in menu window M23, you need proceed to enter additional 4 user-type-wedge parameters that describe the user transducers.

If the PI-type transducer is selected, you need enter additional 4 PI-type transducer parameters that describe the PI-type transducers.

6.22 How to use the circular display function

When entering menu window 95, the circular display function will be started automatically. The following windows will be displayed one by one, each window will stay for 8 seconds: M95>>M00>>M01>>M02>>M02>> M03>>M04>>M05>>M06>>M07>>M08>>M90>>M91>>M92>> M93>> M94>>M95. This function allows the user to visit all the important information without any manual action.

To stop this function, simply press a key. Or switch to a window other than M95.

6.23 How to do the linearity correcting? How to enter into the data?

When the product leaves the factory, the function is closed.

The menu can realize almost 12 parts linearity correcting. The user can choose from two points to twelve points to execute the linearity correcting according to user actual condition.

In order to explain the usage method of the menu, we suppose that we get the following table data through calibration the meter.

Reference standard equipment flow (m ³ /h)	Instrumented show flow (m ³ /h)	Correction coefficient (standard / show value)
1.02	0.0998	1.02
5.11	5.505	0.93
10.34	10.85	0.95
20.45	19.78	1.03
50.56	51.23	0.99

In order to revise the flow exceed the scope of the above table, without mutations of correction factor, we add two points on the basis of the above five points, (0 m³/h, 1.0) and (100000 m³/h, 1.0). (0 m³/h, 1.0) is called the minimum flow of the amendment point, this set of data is used to facilitate to generated a appropriate correction factor when Instrumented show flow under 1.02 m³/h. (100000 m³/h, 1.0) is called the maximum flow of the amendment point, this set of data is used to facilitate to generated a appropriate correction factor when Instrumented show flow above 50.56 m³/h. So that we get the following data sets from small to large.

- (0 , 1)
- (0.0998 , 1.02)
- (5.505 , 0.93)
- (10.85 , 0.95)
- (19.78 , 1.03)
- (51.23 , 0.99)
- (100000 , 1.)

The total is seven sets of data. The next step is to put seven sets of data entered into the Instrument. Pay attention to the input order in accordance with from small to large.

To enter the menu M48, then input the data set number “7”, to be followed in the above seven sets of data, we revised the setup of a multi-segment linearity correcting.

If you need to cancel linearity correcting, simply enter “0” in the menu M48.

Decommissioned linearity correcting, you just need to enter in the menu M48 data points (in this example, it is “7”).

Noted: before the calibration of the instrument, you must first close the linearity correcting function. If under the condition that the linearity correcting function has not closed, the calibration data sets arising from the amendment must be dealing with the reverse curve of the data following the original amendment, then input to the Instrument. Reverse amendment is very complicated, and should be avoided.

6.24 How to save / restore frequently-used pipe parameters

You can use menu window M27 to store or restore from the internal Flash memory, as many as 9 different pipe parameter configurations.

7. Troubleshooting

7.1 Hardware self-diagnosis errors and solutions

The ultrasonic flow meter provides an automatic power-on diagnosis for the hardware problems. When any message (while power on) in the following table displays, counter-measures should be taken.

Table 1.

Error message on LCD	Causes	Counter-measures
ROM Parity Error	ROM operation illegal/ Error	(1)Reboot the system (2)Contact the manufacturer
Stored Data Error	RAM parameters data Error	(1)Reboot the system (2)If problem persists, press ENT key to restore the factory default configuration.
System data memorizer Error	System data storing Error	Power ON again/ Contact with factory
Electro-circuit Hardware Error	CPU electro-circuit Error	Power ON again/ Contact with factory
CPU Clock Speed Error	System clock Error	Power ON again/ Contact with factory
Date Time Error	Number errors with the calendar	Re-set calendar
No Display. Erratic or Abnormal Operation	Problem with wiring	Double check wiring connections
No response to key	Keypad is locked	Unlock the keypad.

7.2 Working status errors and solutions

While under working status, the ultrasonic flow meter will show Error Code in the lower right corner with a single letter like I, R etc., on menu windows M00, M01, M02, M03, M90 and M08. When any abnormal Error Code shows, counter-measures should be taken.

Error code	Correspondent Message displayed on M08	Causes	Counter-measures
R	System Normal	No error	
I	Detect No Signal	(1)No Signals detected (2)Transducers installed improperly (3)Too much fouling (4)Pipe liners are too thick. (5)Transducer cords are not properly connected	(1)Polish the pipe surface and clean the spot. Remove paint (2)Make sure the couplant is enough (3)Make sure the transducer is in tight contact with pipe surface (4) Check the transducer cables (5) Check installation parameters settings (6)Find a better measurement site. Newer pipe, no corrosion, no depostion
J	Hardware Error	Hardware problem	Contact the manufacturer
H	PoorSig Detected	(1)Poor signal detected (2)Transducers installed improperly (3)Too much fouling (4)The pipe liners are too thick. (5)Problem with transducers cords	(1)Relocate measuring place (2)Clean the spot (3)Check the cords (4)Check the coupler

E	Current of loop is bigger than 20mA.	4-20mA loop output over 120% Improper settings for current loop output	<ul style="list-style-type: none"> (1) Ignore it if current loop output is not used (2) Check current loop setting in M56 (3) Confirm if the actual flow rate is too high.
Q	Frequency Output Over	<ul style="list-style-type: none"> (1) The frequency output is over 120% (2) Improper settings for frequency output (3) The actual flow rate is too high 	<ul style="list-style-type: none"> (1) Ignore it if frequency output is not used. (2) Check the values entered in M66,M67,M68,M69 (3) Use a larger value in M69 if needed. (4) Confirm if the actual flow rate is too high.
F	See Table 1	Temporary problems while self-checking with power ON	<ul style="list-style-type: none"> (1) Reboot the system (2) Contact the manufacture
		Permanent problems with hardware	
G	Adjust Gain>S1 Adjust Gain>S2 Adjust Gain>S3 Adjust Gain>S4 (Shown in M00,M01,M02,M03)	Instrument is in the progress of adjusting the gain for the signal, and the number indicates the progressive steps. If stopping at S1 or S2 or between S1 and S2, it means low receiving signal.	No need for action
K	Empty pipe, Setup on M29	No liquid inside pipe or Error setup.	<ul style="list-style-type: none"> (1)If the pipe is not full, relocate the meter to where the pipe is full of liquid. (2)If the pipe is full, enter 0 on M29

7.3 Other Problems and Solutions

Q1. When the actual flow inside the pipe is not standstill, but the instrument displays 0.0000 for the flow rate, and 'R' displaying signal strength and the signal quality Q (value) has a satisfactory value?

RE: The problems are likely caused by the user who has used the 'Set Zero' function on this non-standstill flowing pipe. To solve this problem, use the 'Reset Zero' function on menu window M43.

Q2. The displayed flow rate is much lower or much higher than the actual flow rate in the pipe under normal working conditions.

RE: (1) There is probably an offset value wrongly entered by the user in M44. Enter '0' in M44.

(2) Problem with transducer installation.

(3) There is a 'Zero Point'. Try to 'zero' the instrument by using M42 and make sure that the flow inside the pipe should be standstill.

Chapter 8 Appendix

8.1 Wiring Diagram

The following wiring diagram is for wall mounted ultrasonic flow meters.

The main board of the wall mounted unit is shown in the following picture. All the wiring terminal blocks are located on the lower part of the box. The terminal block pins are numbered and marked right below the pins.

Main PCB Wiring Diagram

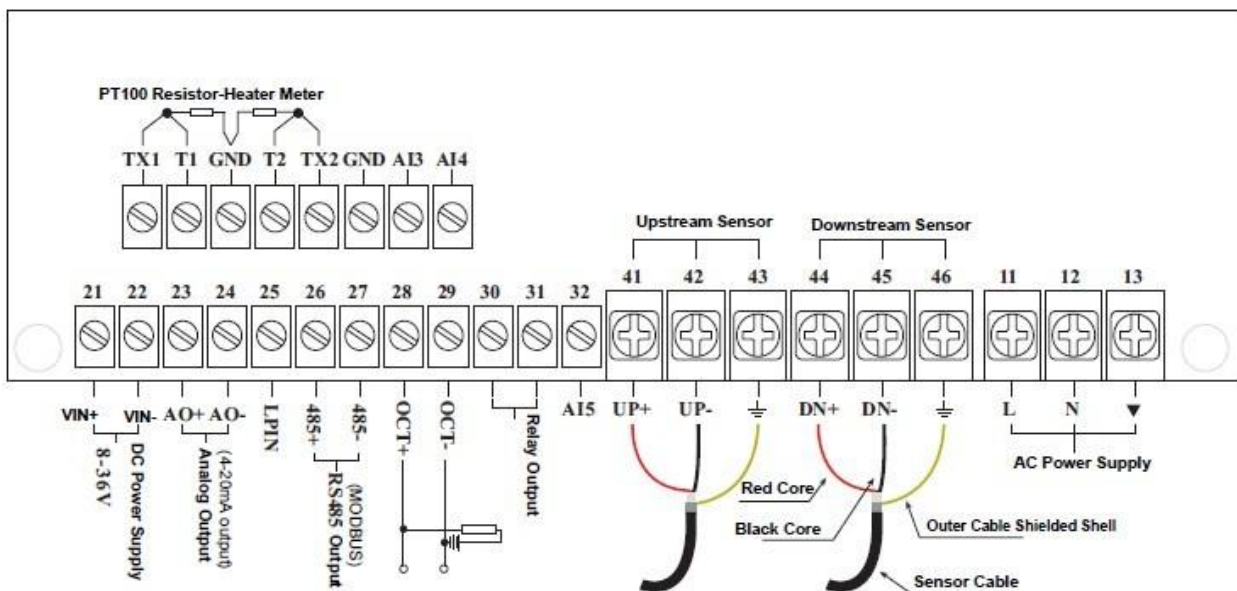

Warranty

The products manufactured by Flowmetrix SA are warranted to be free from defects in materials and workmanship for a period of one year from the date of shipment to the original purchaser. Flowmetrix SA obligation should be limited to restoring the meter to normal operation or replacing the meter, at Flowmetrix SA choice, and shall be conditioned upon receiving written notice of any alleged defect within 10 days after its discovery. Flowmetrix SA will determine if the return of the meter is necessary. If it is, the user should be responsible for the one-way shipping fee from the customer to the manufacturer. Flowmetrix SA is not liable to any defects or damage attributable to miss usage, improper installation, out-of-spec operating conditions, replacement of unauthorized parts and acts of nature. Besides, fuses and batteries are not part of this warranty.

THE FOREGOING WARRANTY IS EXCLUSIVE AND IN LIEU OF ALL OTHER EXPRESS OR IMPLIED WARRANTIES (INCLUDING BUT NOT LIMITED TO WARRANTIES OF MERCHANTABILITY AND FITNESS FOR A PARTICULAR PURPOSE, AND WARRANTIES ARISING FROM DEALING, TRADE OR USAGE.)

Service

For operational problems, please contact the technical support department by telephone, fax, email or internet. In most cases, problems could be solved immediately. For any hardware failure of the instrument, we recommend our customers to send back the instrument for service. Please contact the technical support department with the model number and serial number of the unit before sending the unit back to us. Both numbers can be found on the product label. For each service or calibration request, we will issue a Return Materials Authorisation (RMA) number.

Take notice that the cost for repairing can only be determined after receipt and inspection of the instrument. A quotation will be sent to the customer before proceeding with the service.

Important Notice for Product Return

Before returning the instrument for warranty repair or service, please read the following carefully:

1. If the return item has been exposed to nuclear or other radioactive environment, or has been in contact with hazardous material which could pose any danger to our personnel, the unit cannot be serviced.
2. If the return item has been exposed to or in contact with dangerous materials, but has been certified as hazard-free device by a recognized organization, you are required to supply the certification for the service.
3. If the return item does not have a RMA# associated, it will be sent back without any service conducted.