

EESIFLO EASZ-1

The water in oil monitor that protects your investment

KNOW IMMEDIATELY WHEN A PROBLEM OCCURS IN YOUR OIL SYSTEM

- ✓ LOOP POWERED
- ✓ ONLINE MOISTURE SENSOR
- ✓ IMMEDIATE RESPONSE
- ✓ SITE RE-CALIBRATEABLE
- ✓ NO NEED FOR CONTINUAL SENSOR REPLACEMENT
- ✓ USER SELECTABLE RANGES
- ✓ LIGHTWEIGHT RUGGED CONSTRUCTION
- ✓ AFFORDABLE!

COST EFFECTIVE ,ACCURATE AND STABLE MEASUREMENT WITH TEMPERATURE COMPENSATION

Continuous and accurate monitoring of water contamination in Lubrication Oils, Heavy Fuel Oils and Hydraulic Oils. The EASZ-1 is a unique system which provides Operators of all types of Engines, Turbines, Thrusters, Azipods, Gears, Separators and Stabilizers with a means of continuous monitoring of the oil systems for possible water contamination

Loop Powered Mini Easz-1 Water Content transmitter



Made in Sweden

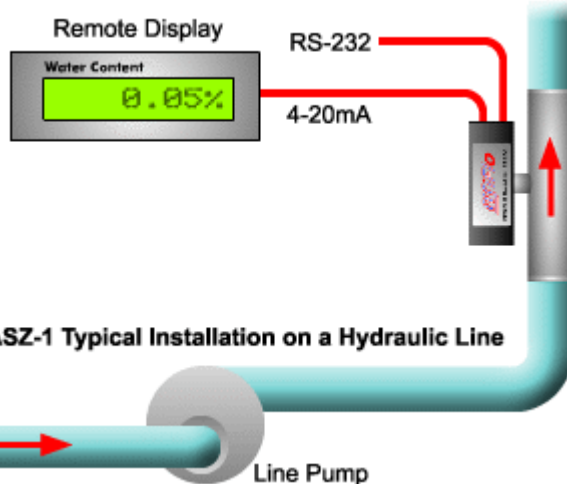

EASZ-1 Typical Installation on a Hydraulic Line

The EASZ-1 temperature compensated microprocessor based loop powered water in oil sensor enables **fast and reliable drift free online detection and monitoring of moisture** percentage or ppm in oil. The EASZ-1 can be used in on-line moisture monitoring and as a control instrument allowing separators and oil purifiers to be started only when needed or as a diagnostic or preventative device protecting critical systems from premature failure. Most important of all is the response time which is seconds. The unit responds very quickly to a change in the capacitance of the oil being monitored and is not affected or knocked out of service by saturation and will continue to work in both high and low measurement ranges.

Water in oil can cause quick and costly breakdowns. They can happen so fast that in many cases, water in oil can be treated as a more serious contamination problem than metal particle contamination!

Water contamination can occur at any time. It is possible that serious damage can be caused on bearings and other lubricated components without the user knowing it is happening. The EASZ-1 water in oil analyzer can give early warning of a problem so that corrective action can be taken.

The EASZ-1 is able to measure water saturated in oil down to PPM levels

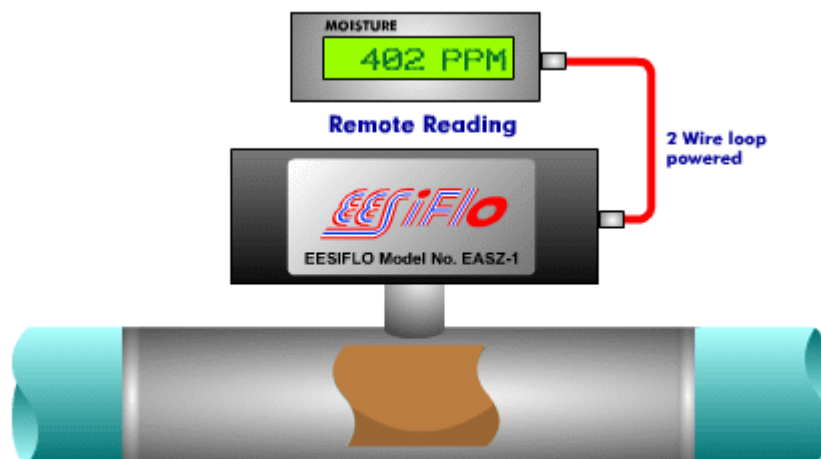

Above is saturated water in oil

The EASZ-1 is an accurate and robust resistive capacitance meter measuring between two co-axis pipes. By applying a sinusoidal signal with a known amplitude and frequency to the inner pipe it is possible to measure the resistive capacitance of the liquid under test.

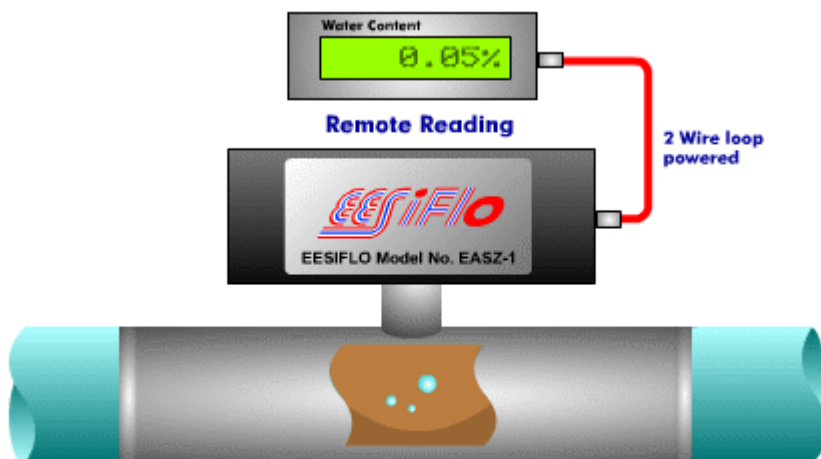

Above shows presence of free water

EESIFLO'S EASZ-1 PREVENTS MACHINE FAILURES

Water contamination drastically reduces the performance of mechanical equipment. Excess moisture or water content can increase the risk of corrosion, overheating, machine malfunction and catastrophic failures causing system shutdowns. Accurate measurement and control of moisture in large lubrication systems is essential for planning, servicing, preventing unscheduled downtime and reduction of overall production costs.

DIRECT READING, FAST RESPONSE, RUGGED, LIGHTWEIGHT AND AFFORDABLE!

The EASZ-1 not only gives you continuous direct readings of oil/water mixtures but also directly measures the amount of free water contamination instantaneously. The EASZ-1 was designed to be an affordable device replacing unreliable spot sampling methods and slow response water activity transmitters which only alert the user if there is a risk of free water contamination and nothing else. The EASZ-1 is an easy to use loop powered transmitter unit using a finely engineered stainless steel capacitance cell and high speed encapsulated microprocessor based electronics resistant to humidity and rugged industrial environments. Most of all, the unit weighs approximately 3 lbs (less than 1 kg) and can be set up and running in minutes. The EASZ-1 can handle oils with different densities and onsite zero calibration (if necessary) can be done simply through the press of a button.

FEATURES/BENEFITS

- **TOTAL water Measurement**
- **Immediate Response to a change of state**
- **Temperature Compensation**
- **Excellent long term stability and drift free**
- **Recalibrate on site if necessary**
- **Easy to install**
- **No maintenance needed**
- **Loop Powered (2 wire) or 24 vdc (other options available)**
- **Analog and RS 232 full duplex Output as standard**
- **User re-configurable range 0-10000ppm, 0-1%,0-3%,0-10% and 0-25%**
- **Lightweight and Robust**
- **Encapsulated Electronics**
- **RS-485 option allows up to 30 units to be connected in series**
- **Optional HART protocol on request**
- **Fully CE Compliant**

EESIFLO MODEL EASZ-1 SPECIFICATIONS

GENERAL

Water in Oil range	0-10000ppm, 0-1%,0-3%,0-10% and 0-25%
Recommended Flow Range	5 to 150 LPM
Resolution	0.01% water
Temperature compensation	Built in Temperature compensation
Temperature range	0-150 °C or 300 °F
Shipping Weight	Approximately 1kg/3lbs

MECHANICAL

Cell Construction Material	316L
Pipe Connection	1 inch NPT thread (other threads/sizes available)
Maximum Temperature	150 °C/300 °F
Pressure Rating	16 Bar /230 psi (higher pressure consult factory)

ELECTRICAL

Power Requirements	Loop Power or 24 vdc (grounded or ungrounded)
Electronic Protection	IP 65
Operating Temperature	-40 °F -185 °F (-40 °C to 85 °C)
Enclosure	Anodized Aluminium Epoxy Coated
Outputs	4-20 mA DC , RS232 Full Duplex ,Optional RS485
Options	Remote readout/display

Dimensional Drawing (mm)

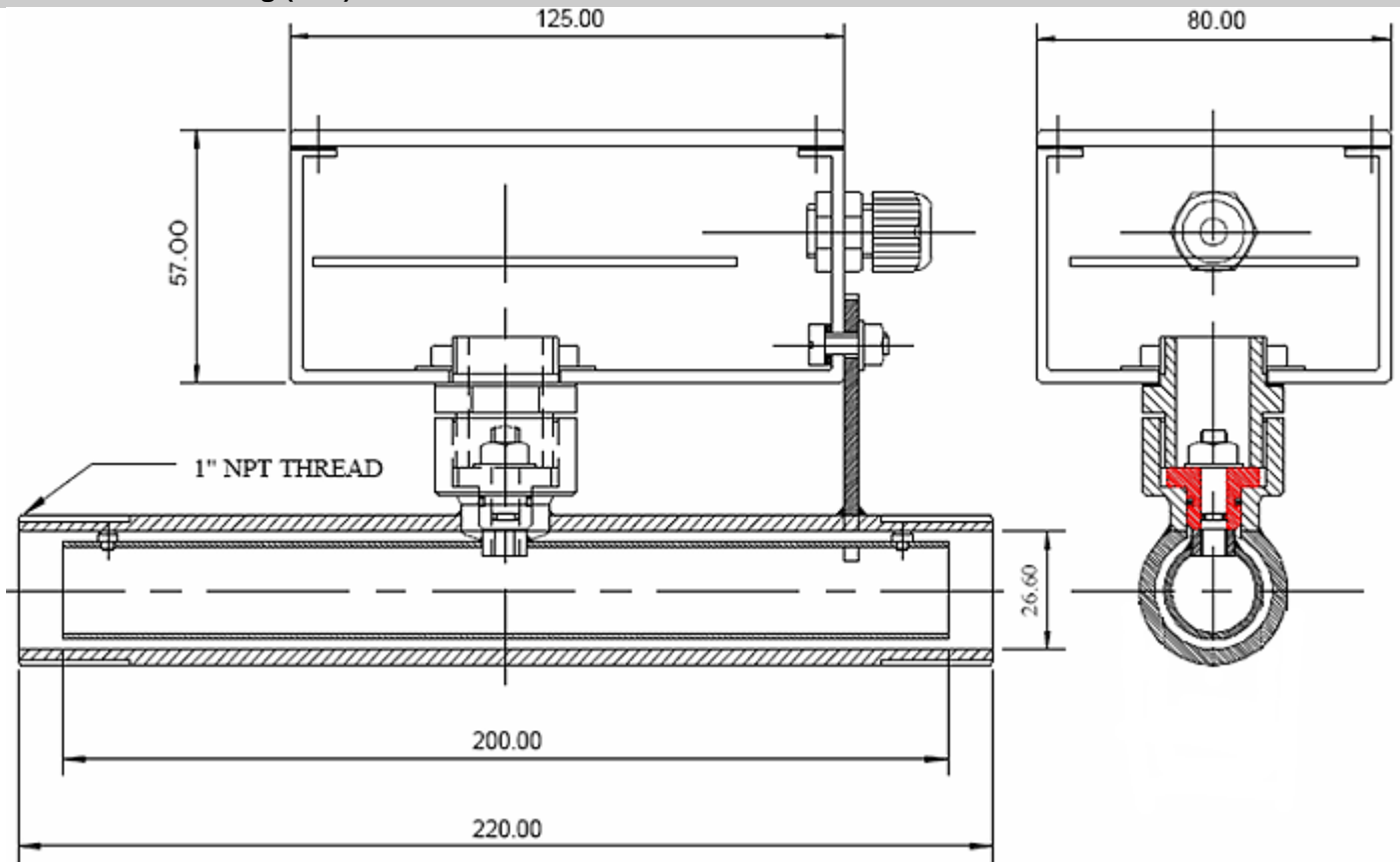

MADE IN SWEDEN

EESIFLO reserves the right to change specifications without notice