

## FLOWMETRIX SA SAFMAG Electromagnetic Flowmeter

Doc Date 16.11.2009



### PERFORMANCE

- \* 0,5% of rate (Standard)
- \* 0,25% of rate (Optional)
- \* 1000 : 1 operable flow range
- \* Excellent repeatability
- \* Optional Bi-directional measurement
- \* Advanced microprocessor technology
- \* Interchangeable converter
- \* ACMPU converter for slurries and pulps
- \* User friendly touch control programming

### RELIABILITY

- \* Rugged design
- \* No moving parts
- \* Fully welded housing for maximum protection
- \* Non-intrusive sensor
- \* Submersible sensors
- \* No electronics in flowtube
- \* Empty pipe detection
- \* Calibration mode diagnostics
- \* Choice of liner and electrodes

Subject to change without notice

Flowmetrix SA  
P.O. Box 17143  
Congella  
Durban 4013  
South Africa

Tel : 086 110 6028  
Fax : 086 516 8460  
email: [enquiries@flowmetrix.co.za](mailto:enquiries@flowmetrix.co.za)  
[www.flowmetrix.co.za](http://www.flowmetrix.co.za)



# FLOWMETRIX SA

## SAFMAG Electromagnetic Flowmeter

### INTRODUCTION

The electromagnetic flowmeter has been a tried and trusted, maintenance-free industrial flow measurement device for many years. It is based on Faraday's law of induction, where a voltage is induced in a conductor when it moves within a magnetic field. The conductive fluid passing through the flowmeter forms the moving conductor, and the induced voltage is proportional to the average flow velocity. Fluids with conductivities of 5 micro-siemens/cm and above can be accurately measured by the SAFMAG. Advantages of using electromagnetic flowmeters include unrestricted pipe cross-section and independence of density and fluid viscosity. Performance is unaffected by changes in process pressure, temperature and fluid conductivity. All of this, plus a linear output signal, make the SAFMAG an ideal flowmeter for a wide variety of applications.

### FEATURES

The SAFMAG utilises a new generation multitasking microprocessor to handle all functions simultaneously. Low power electronics technology reduces total power consumption, therefore realising small power backup systems. The SAFMAG's rugged design and reliability make it the obvious choice when it comes to flow measurement of conductive fluids. Two versions of the signal converter are available:

- ACMPU for use on all slurries, pulps and pastes providing a stable, accurate reading of flow with these traditionally difficult applications.
- DCMPU for use on all other general applications, the pulsed dc technology and continuous automatic rezeroing, making it the recommended choice in these applications. The simple design of the SAFMAG enhances reliability. The flowtube housing is fully welded and pressure tested to ensure a complete seal against moisture and other contaminants. The field wiring is isolated in a separate terminal box, sealed from the coil housing to ensure that the coil housing is not contaminated by possible conduit entry infiltration.

User friendly, self-explanatory input or interrogation of measurement data is done directly on the converter by means of a 4-button keyboard. An easily readable illuminated 2-line display is used to display the flowmeter data. Flow rate and flow total are continuously displayed. Configuration data is stored in nonvolatile EEPROM memory.

### GROUNDING

Electromagnetic flowmeter performance can be compromised by stray currents present in the piping or process fluids. Proper connection of the flowtube to reference the process fluid potential is important. The first rule to be observed is that the flowmeter body and the fluid should be at the same potential. The SAFMAG is supplied with a grounding electrode for this purpose. In process fluids with low conductivity or in cathodic protection situations, it is recommended that two grounding rings located at the upstream and downstream faces of the flowtube are used to ensure a positive process ground.

### SIZING

The flowtube size is an important consideration as it affects flow velocity. It is often necessary to select a meter that is smaller than the adjacent piping to ensure the fluid velocity is suitable for the meter. The following table shows guidelines for sizing meters in different types of applications, although operation outside these limits may also give acceptable performance.

Application	Velocity (m/s)
General	0.5 to 10.0
Abrasive slurries	1.0 to 3.0
Non-Abrasive slurries	1.0 to 5.0

## FLOWMETRIX SA SAFMAG Electromagnetic Flowmeter

### LINING MATERIALS

A variety of lining materials are available to ensure compatibility with most applications.

#### Neoprene

Recommended in applications where a combination of chemical attack and abrasive wear are present. The Neoprene lining has a maximum temperature limit of 80 deg. C.

#### Natural rubber

Recommended for general applications. The abrasion resistance characteristics of natural rubber are very good, but it has poorer chemical resistance than Neoprene in acid service. The maximum temperature limit is 70 deg. C.

#### Polyurethane

Recommended for slurry flows that contain abrasive solids. Polyurethane has limited chemical resistance and has a maximum temperature limit of 50 deg. C.

#### Ebonite

Recommended for higher temperature general applications. Ebonite is a hard rubber, and has a maximum temperature limit of 95 deg. C.

#### PTFE

Recommended in applications where chemical attack is likely, it has fair resistance to abrasive wear. Very few materials adhere well to PTFE, so coatings that might build up on other linings will usually not adhere to the surface. It has good high-temperature capabilities with a maximum limit of 150 deg. C.

Table of meter capacities for minimum and maximum full scale velocities

METER SIZE (mm)	FLOWRATE @ 1m/s		FLOWRATE @ 10m/s	
	(l/s)	(m <sup>3</sup> /h)	(l/s)	(m <sup>3</sup> /h)
25	0.5	1.75	5.0	17.5
40	1.25	4.5	12.5	45
50	2	7	20	70
65	3.3	12	33	120
80	5	18	50	180
100	8	28	80	280
125	12	44	120	440
150	18	64	180	640
200	31	113	310	1130
250	49	176	490	1760
300	70	254	700	2540
350	96	346	960	3460
400	125	452	1250	4520
450	159	572	1590	5720
500	196	707	1960	7070
600	283	1018	2830	10180
700	385	1385	3850	13850
750	442	1590	4420	15900
800	500	1800	5000	18000

## FLOWMETRIX SA

### SAFMAG Electromagnetic Flowmeter

---

The company's policy is one of continuous product improvement and the right is reserved to modify the specifications contained herein without notice.

#### Performance specification

System specifications are stated at reference conditions with frequency output. The flowtube is calibrated against a reference DCMPU flowmeter.

##### Accuracy

Display and frequency output  
± 0.5% of rate for velocity > 0.5m/s  
± 0.025% of full scale for velocity < 0.5m/s

##### Analog output

above error plus ± 0.008mA

##### Repeatability

± 0.1 % of rate

##### Temperature effect

± 0.01 % per deg. C

##### Sensor mounting

Directly into pipeline at any attitude, ensuring that the flowtube remains completely full

##### Separation

Maximum recommended distance between the flowtube and the remote mounted signal converter is 100 metres

#### Sensor specification

The SAFMAG sensors are available in flanged format.

##### Sizes (nominal bore)

25mm to 800mm

##### Process connections

Flat face steel flanges to mate with specified flange pattern (mild steel as standard)

##### Metering tube

304 stainless steel

##### Pressure

Maximum pressure dictated by flange rating  
25mm to 150mm - 1600KPa as standard  
sizes > 150mm - 1000KPa as standard  
For higher pressure consult factory

##### Electrodes: Non-removable

316 stainless steel, Hastelloy C,  
Tantalum, Titanium (other - consult  
factory)

##### Earth electrode

Fitted as standard  
Earthing rings available as an option

##### Lining material

##### (temperature limits)

Neoprene	-10 °C to 80 °C
Natural rubber	-10 °C to 70 °C
Polyurethane	-10 °C to 50 °C
Ebonite	-10 °C to 95 °C
PTFE	-20 °C to 150 °C

##### Temperature

Sensors: refer to limitations of lining material

##### Environmental protection

Sensors: IP68  
Sensors with integral transmitter: IP65

##### Sensor housing

Rolled 3CR12 cover welded to steel side panels

##### Paint

Polyurethane acrylic enamel

##### Terminal box

Epoxy coated cast aluminium

##### Electrical connections (terminal box)

Two 20mm IP68 glands

## FLOWMETRIX SA SAFMAG Electromagnetic Flowmeter

Weights	
Size (mm)	Flowtube weight (kg)
25	10
40	12
50	20
65	22
80	23
100	27
125	30
150	42
200	60
250	80
300	100
350	140
400	190
450	220
500	280
600	420
700	500
750	560
800	650

Approximate values only - actual weights will vary dependent on the flange and pressure rating. Remote electronics weight 4 kg.

### Signal converter specification

The DCMPU signal converters are available for remote mount or integral mount. ACMPU signal converters are available only as remote mounted units. Both are capable of processing signals from fluid velocities between 0.01 and 10.0m/s for all flowtube sizes. Full scale is adjustable between 1 and 10m/s.

#### Interchangeability

Converters are fully interchangeable with all sizes of flowmeters and configurable on site. A DCMPU converter must be replaced with another DCMPU and likewise for an ACMPU. Flowtubes are flow-calibrated and assigned a calibration factor at the factory. This calibration factor is entered into the converter, enabling interchangeability.

#### Conductivity

Process fluid must have a conductivity of at least 5 micro-siemens/cm.

#### Display

Flow total and flow rate are continuously displayed on the 2 - line LCD display with LED backlight

#### Power supply

DCMPU 115V or 230V ac  $\pm$  10%, 50/60Hz, 12 - 30V dc  
ACMPU 115V or 230V ac  $\pm$  10%, 50Hz ONLY

#### Power consumption (tube plus signal converter)

20VA maximum - DCMPU  
250VA maximum - ACMPU

#### Ambient temperature limits

-10 °C to +50 °C

#### Output signals

4 - 20mA (isolated output).  
24V active pulse (isolated output)

#### Analog output adjustment

Engineering units for flowrate are user selected. Output scaled to provide 20mA at the selected maximum flow value.

#### Pulse width

Adjustable from 10ms to 200ms

#### Software lockout

Changes in configuration data protected by user entered password.

#### Output testing

Converter may be commanded to supply a specified output current.

#### Low flow cutoff

Adjustable. Below selected value outputs are driven to zero.

#### Damping

Adjustable between 0.25 and 40 seconds.

# FLOWMETRIX SA SAFMAG Electromagnetic Flowmeter

DIMENSIONS (in mm) flowtube without integral converter or terminal box				
Meter size NB	Dimensions			
	A		B	C
	MS	MX		
25	-	200	200	160
40	220	200	210	170
50	300	200	245	205
65	300	200	275	235
80	300	200	275	235
100	300	250	300	260
125	300	250	300	260
150	420	300	355	315
200	420	350	415	375
250	480	450	470	430
300	480	500	525	485
350	580	550	585	545
400	620	600	645	605
450	680	650	705	665
500	720	700	775	735
600	820	800	890	850
700	920	900	1020	980
750	980	950	1080	1040
800	1020	1000	1140	1100

MX 'A' Dimension size 400mm and smaller as ISO/DIS 13359 Standard

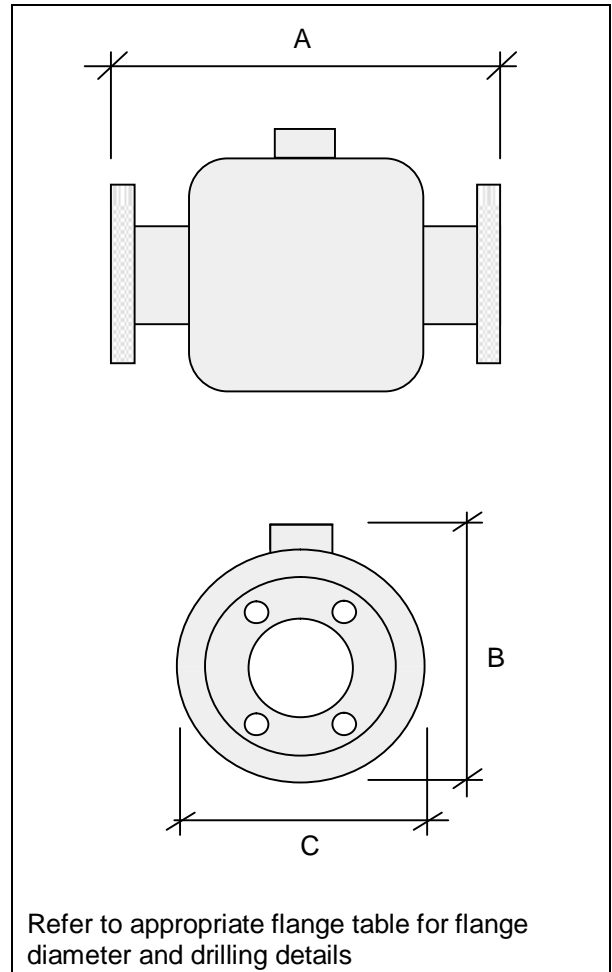

Refer to appropriate flange table for flange diameter and drilling details

