

FLOWMETRIX SA

SAFMAG Electromagnetic Flowmeter

Doc. Date: 30/05/2007

**INSTRUCTION
MANUAL**

**SAFMAG
ELECTROMAGNETIC FLOWMETER**



FLOWMETRIX SA

SAFMAG Electromagnetic Flowmeter

TABLE OF CONTENTS

SECTION 1. GENERAL INFORMATION

1.1	Introduction	1
1.2	Identification	1
1.3	Inspection	1
1.4	Damaged Parts	1

SECTION 2. SAFMAG ELECTROMAGNETIC FLOWMETER

2.1	Theory of Operation	2
2.2	Description	3
2.2.1	General	3
2.2.2	Meter Body	3
2.2.3	Electronics	4
2.3	Application Guidelines	4
2.4	Conductivity	5
2.5	Installation	6
2.5.1	Piping and Other Considerations	6
2.5.2	Installation Procedure	7
2.5.3	Electrical Connections	9
2.6	Start-up and Operation	13

SECTION 3. CALIBRATION

3.1	Factory Calibration and programming	13
3.2	Calibration Coefficient	14
3.3	Re-calibration	14

SECTION 4. SERVICING

4.1	Inspection and Maintenance	19
4.2	Troubleshooting	19

SECTION 5. SPECIFICATIONS 22

SECTION 6. WARRANTY 24

FLOWMETRIX SA

SAFMAG Electromagnetic Flowmeter

SECTION 1 General Information

1.1 Introduction

The SAFMAG series of electromagnetic flowmeters was introduced by Flowmetrix during 1989, SAFMAG is the first wholly South African designed and manufactured electromagnetic flowmeter.

The SAFMAG has the following standard features, which make it unrivalled for value and reliability:

- 100% Local Content and Support
- No moving parts
- Integral or remote electronics
- Isolated mA and pulse outputs
- AC or pulsed DC excitation
- Weatherproof and submersible construction
- Choice of liner and electrode materials

This manual covers the theory of operation, installation and field service procedures for the full range of SAFMAG products. Should further support be required, contact your local representative or Flowmetrix SA directly.

1.2 Identification

Before beginning installation of the SAFMAG flowmeter, verify that all parameters of the intended application match those of the flowmeter supplied.

1.3 Inspection

Upon delivery the packing case should be inspected for external damage. If damage is evident this fact must be reported to the carrier immediately and the case should only be unpacked with a representative of the shipping company present. Check the contents of the case against the packing slip.

1.4 Damaged Parts

Damaged or defective parts should be returned to the supplier prepaid. Do not return goods until authorisation to do so has been obtained. Returned goods must have accompanying them a letter stating the following:

- Your company name and order number
- The contact person at your company
- Serial number and name of part
- Description of damage and cause if known
- Nature of any repair attempted by the user
- Type of repair, replacement or adjustment requested.

FLOWMETRIX SA

SAFMAG Electromagnetic Flowmeter

SECTION 2. SAFMAG Electromagnetic Flowmeter

2.1 Theory of Operation

The operation of an electromagnetic flowmeter is explained by reference to Faraday's law of electromagnetic induction. This law states that the voltage induced across an electrical conductor, as it moves at right angles through an electromagnetic field, is directly proportional to the velocity of that conductor through the field. Mathematically this statement is represented as shown below:

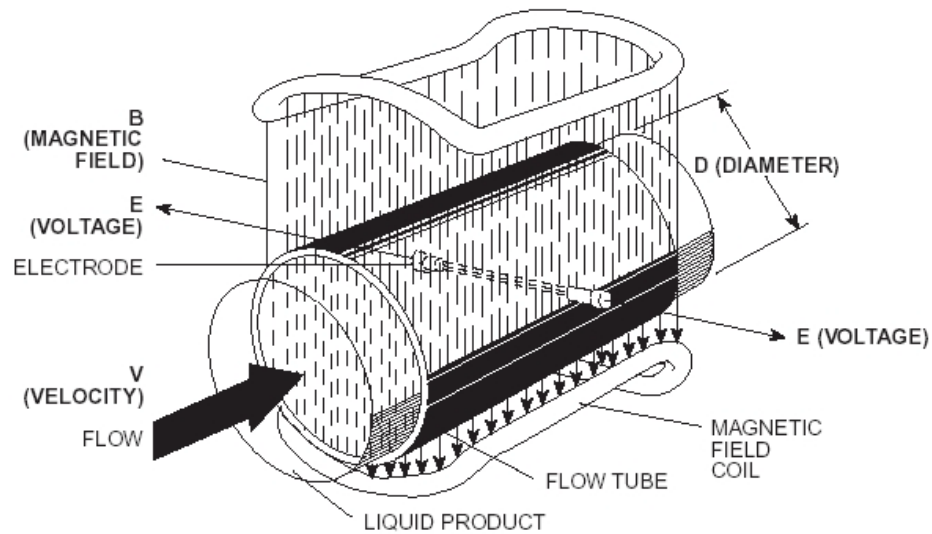

$$E = \text{constant} \times B \times L \times V$$

Where :

E = the induced voltage

B = the electromagnetic field strength

L = the length of the conductor in the field

V = the velocity of the conductor (average velocity of the medium)

The volumetric flow of a conducting liquid or slurry is derived as follows:

Let $L = D$ (the diameter of the meter)

Then $E = \text{constant} \times B \times D \times V$

Volumetric flow $Q = V \times A$ (where A is the Cross-sectional area of the pipe)

Combining the above equations it is seen that if field strength is held constant then $E = KQ$ (where K is a constant), thus *the induced voltage is directly proportional to the volumetric flowrate.*

FLOWMETRIX SA

SAFMAG Electromagnetic Flowmeter

2.2 Description

2.2.1 General

The SAFMAG electromagnetic flowmeter is composed of two principle assemblies. The meter sensor, which is mounted in the pipeline and the flowmeter signal converter which, depending on the option chosen, can be mounted integrally as part of the meter body or remotely mounted.

2.2.2 Meter Sensor (Flowtube)

Flowmetrix manufactures two versions of flowtube

Viz. **Ms** (imperial length) &
 Mx (ISO length)

The **Ms** was the original design and has a higher magnetic field strength than the **Mx** version. Although the **Ms** version is still supplied for the USA market, the **Mx** version is more acceptable in markets that favour the inter-changeability of flowtubes designed to the ISO flange-to-flange overall length.

Many **Ms** (imperial length) flowtubes are operational in the field. The DC pulsed signal converters utilising version 5.10 operating programs therefore provide a menu option to select the flowtube type.

The pipeline section of the meter sensor is constructed from non-magnetic stainless steel and has carbon steel, or optionally stainless steel, pipe flanges welded onto either end in order to form a spool piece. The pipeline section, or flowtube, is then lined with an insulating material compatible with the process to be monitored and chosen from the following options:

- Polyurethane
- PTFE
- Natural Rubber
- Neoprene
- Ebonite

Two field coils are mounted on the flowtube, and these field coils generate the electromagnetic field inside the pipe section. As conductive liquid flows through this pipe section, a voltage is generated. In order to sense the voltage induced in the process fluid, electrodes are inserted through the lining and flowtube. These electrodes are chosen so as to be compatible with the process fluid and are chosen from one of the following options:

- Stainless steel (grade 316)
- Monel
- Hastelloy 'C'
- Titanium
- Tantalum

FLOWMETRIX SA

SAFMAG Electromagnetic Flowmeter

2.2.3 Electronics

The SAFMAG offers two types of coil excitation

- Pulsed DC excitation
- AC excitation

Pulsed DC excitation is normally used when the process fluid is a pure liquid.

In the pulsed DC magmeter, the drive circuit in the electronics unit sends low-frequency pulses to the coils to generate the magnetic field. The frequency of these pulses is selectable, and although the higher frequencies result in a faster response from the flowmeter, the size of the meter limits the frequency that can be used.

The advantage of using pulsed DC excitation, is that zero shift is eliminated, and the need for zero adjustment falls away.

AC excitation is used with slurries and pulp mixtures.

In the AC excited magmeter, line voltage is applied directly to the coils to generate the magnetic field. This system produces an accurate, reliable, fast responding flowmeter, but it has its drawbacks. The varying magnetic field induces a voltage in the electrode wires.

Consequently, the signal converter sees two signals, only one of which represents the flow signal. For successful flow measurement, the flow signal must be separated, and this is achieved at the factory with a full pipe under no flow conditions.

In certain slurry applications, noise is generated as a result of particles impinging upon the electrodes, and the higher frequency of the AC excited magmeter offers a solution to these more difficult applications.

Paper stocks are more complicated, but the chemical additives found in various paper stocks make it difficult to predict accurately whether or not noise will be a problem.

Pulsed DC Excitation – model DCMPU

The DCMPU utilises a multi-tasking Microprocessor electronics to handle all functions simultaneously. The Flowmetrix philosophy of producing easy-to-use instrumentation means that the unit can be programmed in a matter of minutes, even without the instruction manual. The unit is menu driven, and only three menus are needed for all set-up requirements. The flow rate and total are displayed continuously on a backlit LCD display, clearly visible through the viewing window in the cast aluminium housing.

AC Excitation – model ACMPU

The ACMPU is descriptively the same as the DCMPU. The units are identifiable by reference to the description on the label.

2.3 Application Guidelines

The minimum flow velocity through the SAFMAG magmeter at full scale, should not be less than 1 metre/second. The meter diameter should therefore be selected accordingly.

Where abrasive slurries are being handled it is recommended that the velocity should not exceed 3 metres/second. In cases where the process fluid contains particles, which may tend to build up on the pipe wall the velocity should not be less than 1 metre/second. In cases where very dense slurries are being transported, the flow velocity may well need to be in excess of 3 metres/second in order to avoid the particles settling out in the pipe. In this case the useful life of the flowmeter lining may be reduced and consideration should be given to the installation of protective grounding rings.

FLOWMETRIX SA

SAFMAG Electromagnetic Flowmeter

The SAFMAG electromagnetic flowmeter has a minimum full-scale velocity of 1 metre/second and a maximum full-scale velocity of 10 metres/second. Velocity is calculated from volumetric flowrate by using the following equation:

$$V = 1273.24 Q/D^2$$

Where: Q is the flowrate in litres/sec
D is the nominal meter size in mm

The table below gives meter capacities for minimum and maximum full scale velocities, for all meter sizes

METER SIZE (mm)	FLOWRATE @ 1m/s		FLOWRATE @ 10m/s	
	(l/s)	(m ³ /h)	(l/s)	(m ³ /h)
025	0.5	1.75	5.0	17.5
040	1.25	4.5	12.5	45
050	2	7	20	70
065	3.3	12	33	120
080	5	18	50	180
100	8	29	80	290
125	12	44	120	440
150	18	65	180	650
200	31	113	310	1130
250	49	176	490	1760
300	70	254	700	2540
350	96	346	960	3460
400	125	452	1250	4520
450	159	572	1590	5720
500	196	707	1960	7070
600	283	1018	2830	10180
700	385	1385	3850	13850
750	442	1590	4420	15900
800	500	1800	5000	18000

2.4 Conductivity

The first parameter to consider in deciding whether or not to use a magnetic flowmeter in a given application is conductivity. The conductivity unit of measure is microsiemens/cm or ($\mu\text{S}/\text{cm}$). The minimum conductivity level for the SAFMAG is 5 $\mu\text{S}/\text{cm}$. Within wide limits the conductivity of the liquid has no affect on the calibration of a magmeter. This is because conductivity is the reciprocal of resistance; therefore, as the conductivity of the liquid drops, the resistance increases.

FLOWMETRIX SA

SAFMAG Electromagnetic Flowmeter

Consider the following:

In an electrical series circuit, the voltage drops across the impedance's in the circuit must equal the applied voltage. In the equivalent circuit of a magmeter, the applied voltage is the flow signal picked up at the electrode, Z_o is the output impedance of the flowtube, and Z_i is the input impedance of the signal converter.

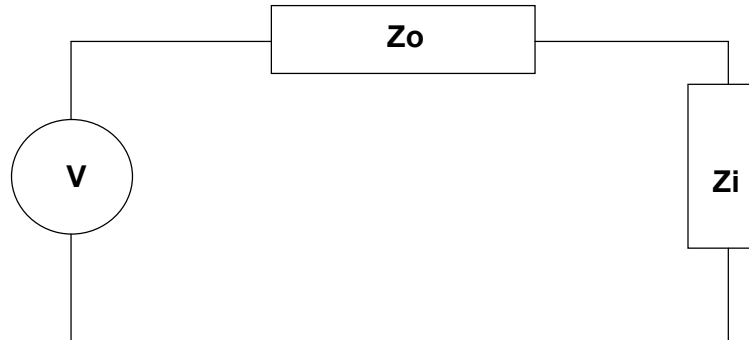

Now, % reduction in span = $Z_o / (Z_o + Z_i) \times 100$

The SAFMAG microprocessor signal converter utilises screen drivers to achieve high input impedance. The input signal from the electrode is buffered and applied to the electrode shields to provide protection against capacitance losses and process-generated noise. The input impedance is in excess of 10^{12} ohms.

The output impedance of the flowtube Z_o is essentially the impedance of the process fluid, so it is necessary to convert conductivity to impedance, in order to calculate the percent span shift at differing conductivities.

For 1 microsiemen/cm ($Z_o = 10^6$ ohms), % error = 0,0001%

For 1000 microsiemen/cm ($Z_o = 10^3$ ohms), % error = 0,0000001%

It is clear from the above that even at conductivity's as low as $1\mu\text{S}/\text{cm}$ the span shift is insignificant if only the signal converter input impedance is taken into account. However, the signal cable will affect the Z_i and must also be taken into account.

FLOWMETRIX SA

SAFMAG Electromagnetic Flowmeter

2.5 Installation

2.5.1 Piping and Other Considerations

The SAFMAG electromagnetic flowmeter is a bi-directional device and as such may be installed in the pipeline either way round. The arrow on the flowmeter body indicates the direction of flow used during calibration. If the meter is installed in the pipeline in the opposite direction to that used for factory calibration it will read zero under all flow conditions. This situation can be remedied by reversing the connections marked "FIELD COILS" on the electronics board.

The meter may be installed in horizontal or vertical pipelines. If a vertical pipeline installation is envisaged the meter should be installed with the direction of flow being **upwards**, to ensure a **full pipe** under low flow conditions. If a horizontal installation is envisaged the meter electrodes should be installed in the horizontal plane in order to prevent entrained air or gasses collecting at the upper electrode. The effect of this would be that the meter would give inaccurate and unstable readings.

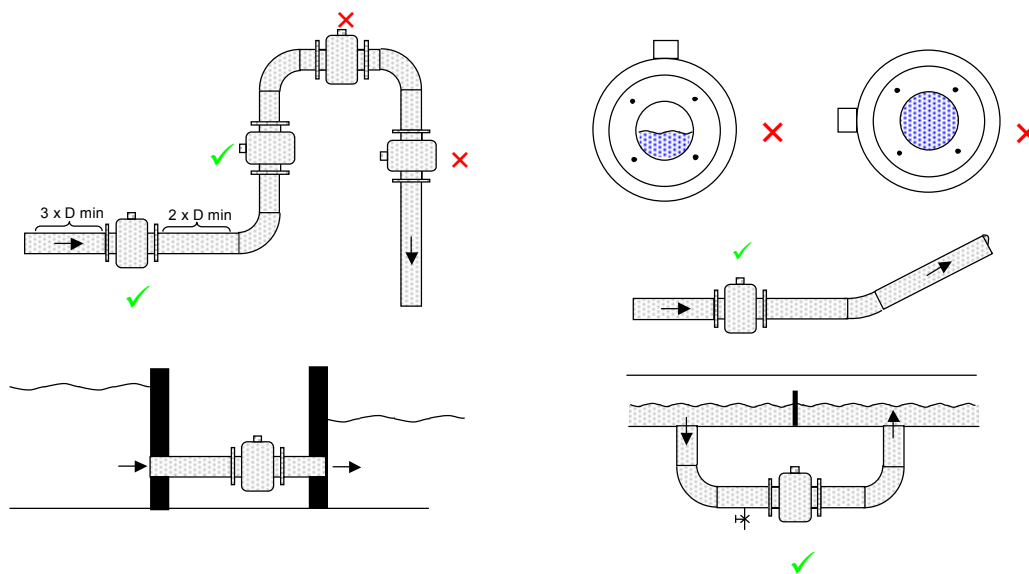

It is essential that the meter be full of liquid at all times.

If this is not the case then the meter will produce an artificially high flowrate. If obtaining a full meter is a problem, in some cases this may be solved by repositioning the meter at the lowest point in a "U" shaped pipe section.

Stray electromagnetic or electrostatic fields of high intensity may have an effect on the meter reading. For this reason the meter should not be installed close to large electric motors, transformers, communications equipment etc.

To ensure accurate flow measurement, the magmeter should be installed with at least 3 pipe diameters of straight pipe upstream, and 2 pipe diameters downstream of the magmeter.

FLOWMETRIX SA

SAFMAG Electromagnetic Flowmeter

2.5.2 Installation Procedure

Meter Body

The flowmeter should be lifted by a rope sling being passed around the outside of the meter or, in the case of the large meters the lifting lugs should be used. Never pass a cable or beam through the flowtube for lifting purposes, as this will damage the flowtube liner and render the meter unusable. Do not support the meter by its case.

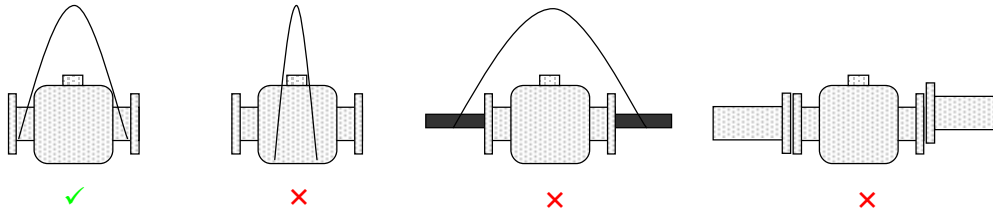

Check for alignment and spacing of pipework, as the meter should not be used to pull pipework into alignment. Table overleaf gives face to face and overall dimensions for the various sizes and types of meter.

Place flange gaskets on the flange faces of the meter and position the meter between the flange faces of the piping. Gaskets should be cut 3 mm larger than the inside diameter of the pipe.

Insert bolts through the flanges and run washers and nuts onto the bolts. Check the piping for alignment and the gaskets for concentricity. Tighten the nuts evenly – do not over tighten as this may damage the liner. Bolt torque should be limited to that which will produce a positive seal.

Remote Electronics

The remote electronics unit may be mounted up to 100 metres from the meter body. It should be mounted on the wall or a pipe stand using normal engineering procedures and safety procedures.

FLOWMETRIX SA

SAFMAG Electromagnetic Flowmeter

DIMENSIONS (in mm) flowtube without integral converter or terminal box				
Meter size NB	Dimensions			
	A		B	C
	MS	MX		
25	-	200	200	160
40	220	200	210	170
50	300	200	245	205
65	300	200	275	235
80	300	200	275	235
100	300	250	300	260
125	300	250	300	260
150	420	300	355	315
200	420	350	415	375
250	480	450	470	430
300	480	500	525	485
350	580	550	585	545
400	620	600	645	605
450	680	650	705	665
500	720	700	775	735
600	820	800	890	850
700	920	900	1020	980
750	980	950	1080	1040
800	1020	1000	1140	1100

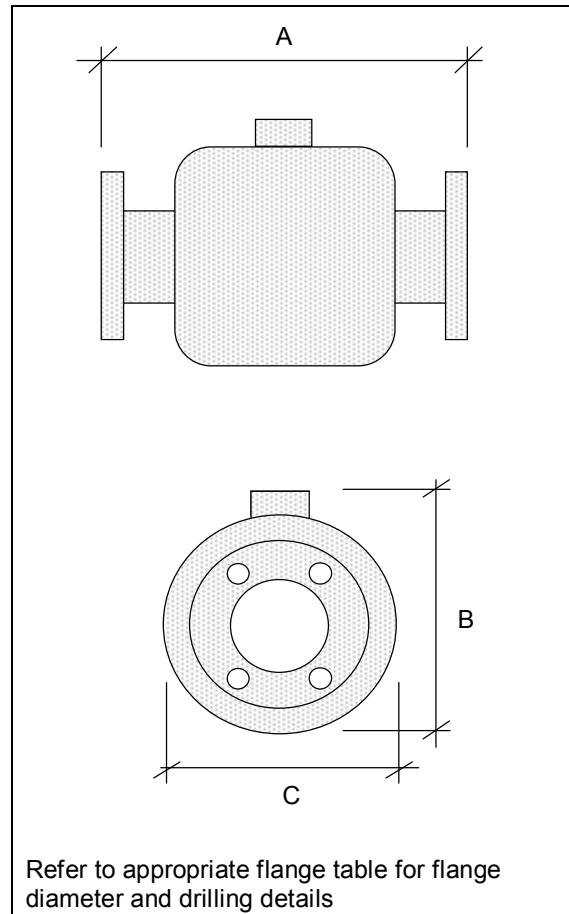

MX 'A' Dimension size 400mm and smaller as ISO/DIS 13359 Standard

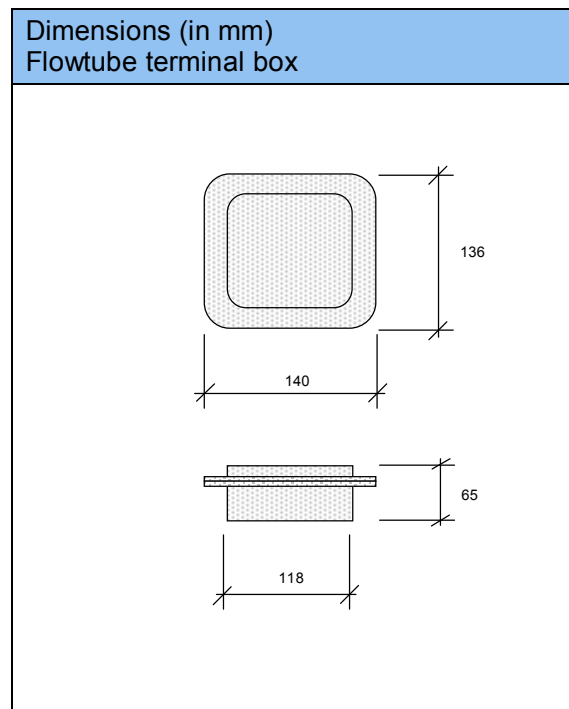
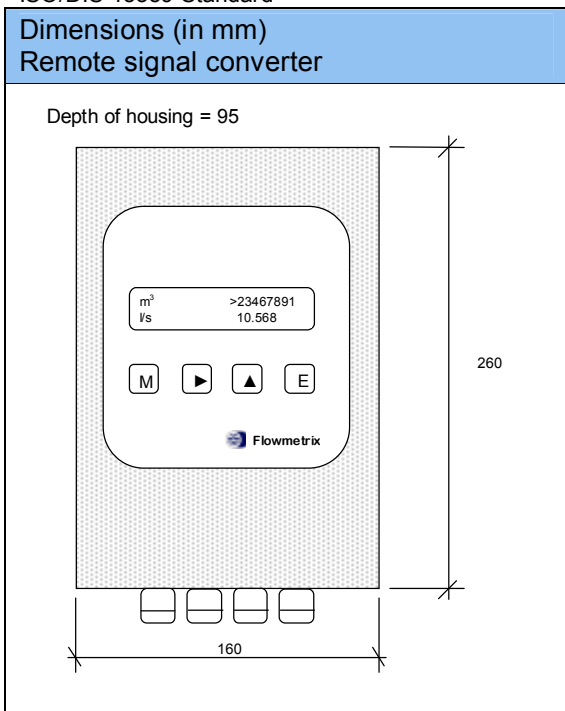

FLOWMETRIX SA

SAFMAG Electromagnetic Flowmeter

2.5.3 Electrical Connections

The first rule to be observed is that the flowmeter body and the fluid should be at the same potential, to ensure accurate measurement. Normally the grounding electrode in the flowtube, or the metal pipeline ensures that the potentials are equalised. Certain installations however, require special consideration:

Unlined metal pipelines (fig a)

In most installations where the flowtube is installed between the flanges of an unlined metal pipeline, the grounding electrode will be sufficient for accurate measurement. Where the process fluid has low conductivity, or if there is a possibility of induced currents in the pipeline, additional precautions should be taken.

Plastic or lined pipelines (fig b)

The grounding electrode will ensure accurate measurement on flowmeters up to 150 mm in size. Above 150 mm, additional precautions may be necessary. Caution ! Ensure the grounding rings are corrosion-resistant!

Pipelines with cathodic protection (fig c)

Pipelines with electric corrosion protection are generally insulated inside and outside so that the fluid has no conductive connection to ground. The flowtube must be insulated from the pipeline.

NB. When installing the flowmeter, ensure that the grounding rings are insulated from the pipe flanges on both sides of the flowtube. Grounding rings, flowtube and measuring ground must be interconnected.

Bypass the flowtube and the grounding rings with a conductor of sufficient current carrying capacity to pass the cathodic protection current with negligible voltage drop.

Customer supplied grounding and connecting cables must have a cross section of 6mm² and be terminated with cable lugs.

Flowmeters supplied with integrally mounted electronics have all connections positions clearly marked on the circuit board. Refer to the connection diagram for details.

Flowmeters supplied with remote electronics require the use of two lengths of special cable supplied by FLOWMETRIX for the connections between the meter body and the remote electronics module. Refer to the connection diagram for details.

Normal electrical and safety practices should be followed when making the electrical connections.

NB. AC supplies should not be run in the same cable as mA or pulse signals. If the 12-30 volt DC supply option is being used it is permissible to combine the DC supply and the measurements signal in the same cable. Screened cable should be used for all measurement signals. In the case of combining DC supply and measurement signals in the same cable, all pairs of cores should be individually screened.

FLOWMETRIX SA

SAFMAG Electromagnetic Flowmeter

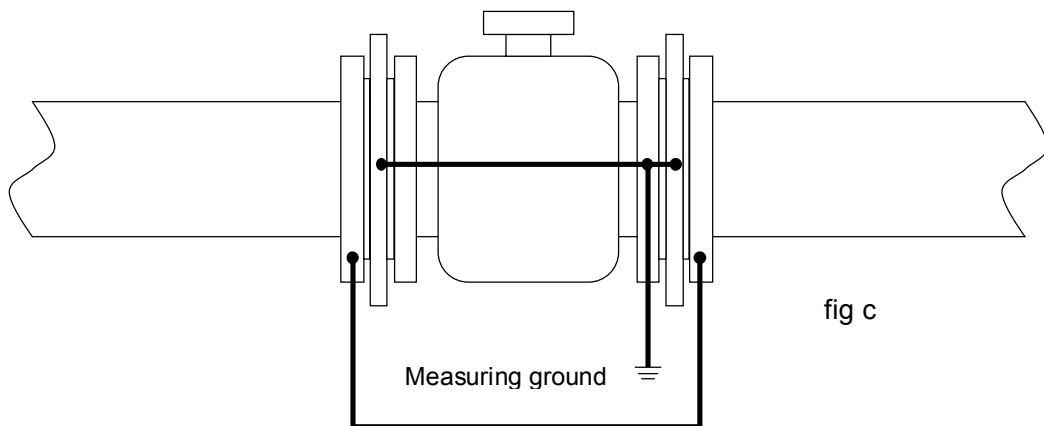
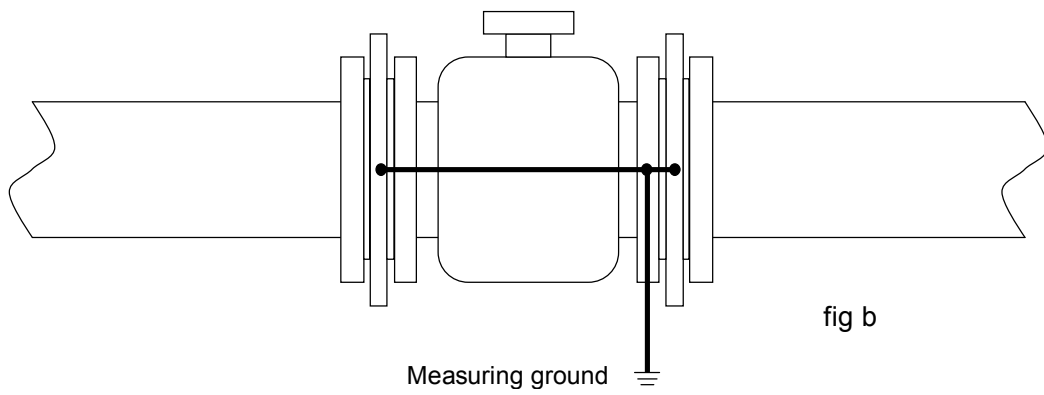
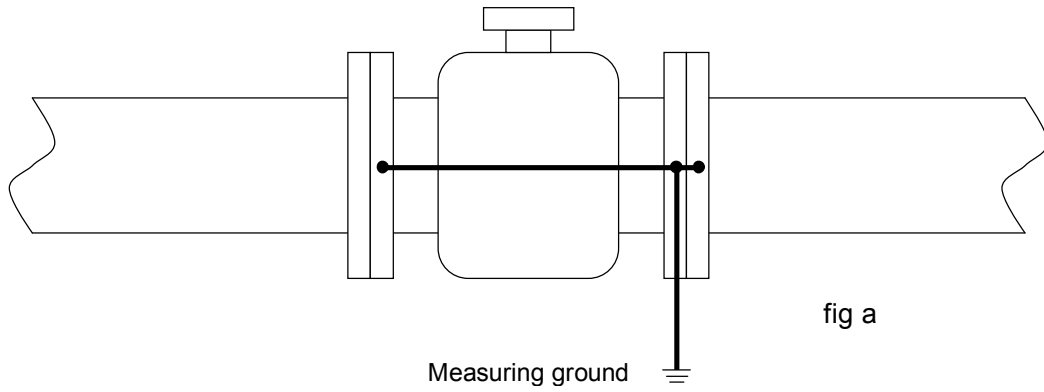

FLOWMETRIX SA

SAFMAG Electromagnetic Flowmeter

Connection diagram for remote mounted signal converter (Serial No's up to 02085600)

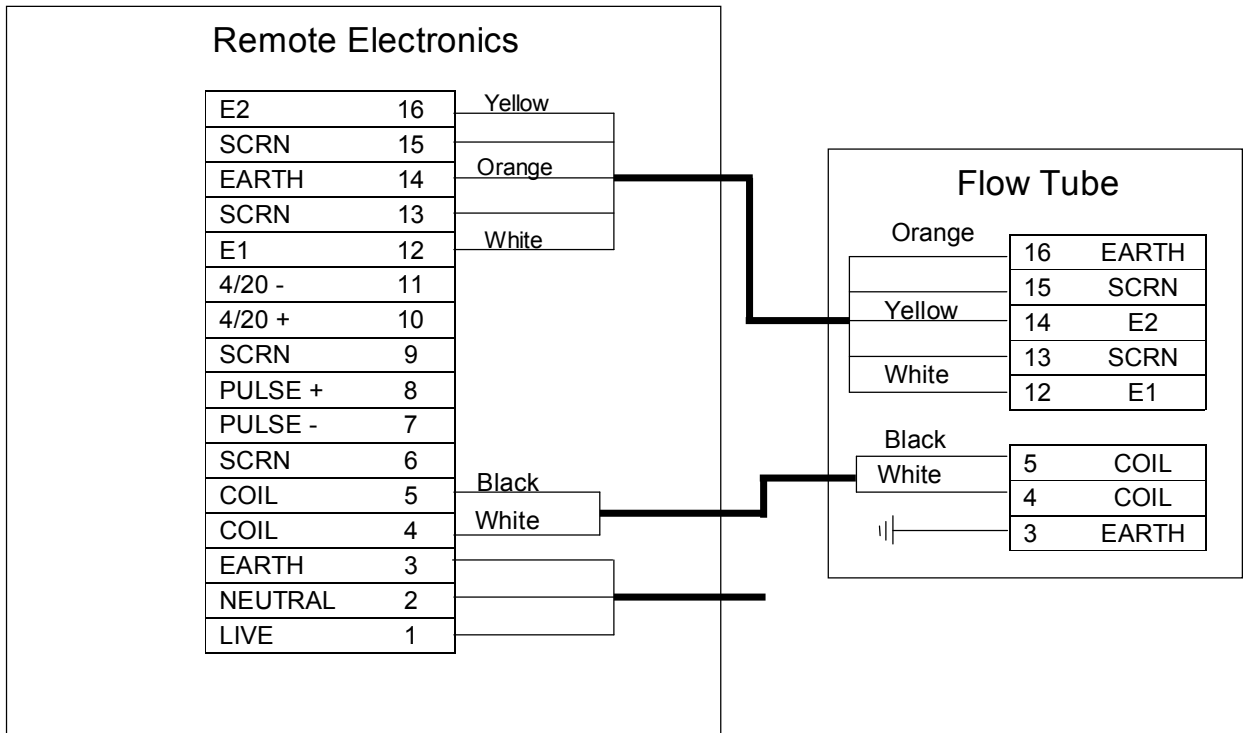

Connection diagram for remote mounted signal converter (Serial No's from 02085601)

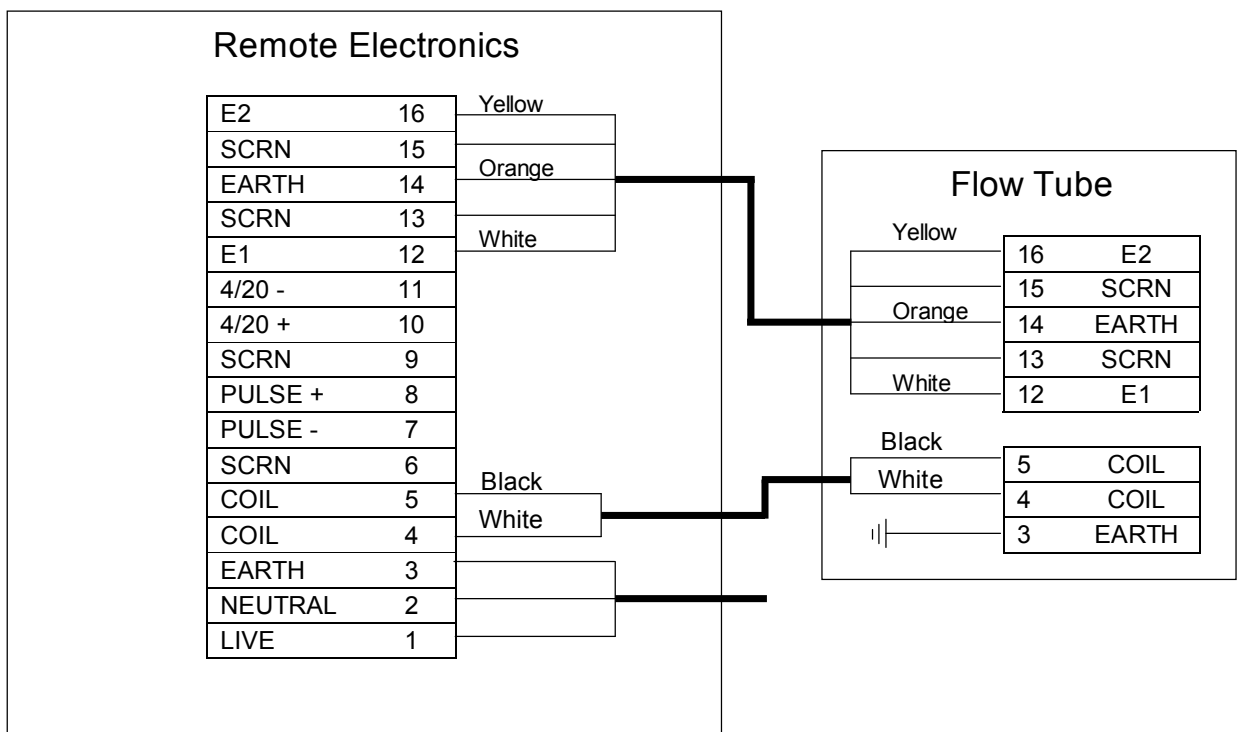

FLOWMETRIX SA

SAFMAG Electromagnetic Flowmeter

Connection diagram for integral mounted signal converter

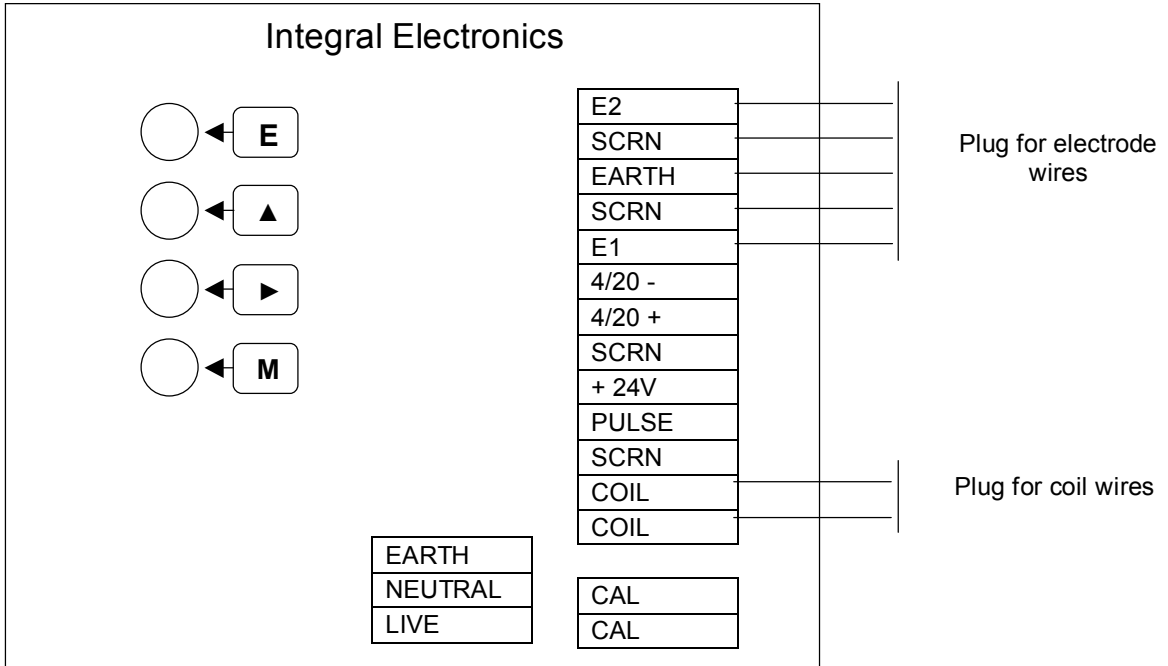

FLOWMETRIX SA

SAFMAG Electromagnetic Flowmeter

2.6 Start-up and Operation

Before powering up the meter, consider the following:

- Is the meter installed according to the direction of flow as marked on the meter
- Has the wiring been carried out correctly and have all safety procedures been adhered to
- Is the supply voltage correct
- Has the flowmeter been properly earthed
- Lethal power supply voltages may be present, do not apply power with the electronics module cover or terminal box cover removed

The SAFMAG is not suitable for installation in areas where explosive or flammable gas, vapour or dust is present.

To put the SAFMAG into operation, allow the pipe work to fill with liquid. Purge all air from the pipe work and turn on the power. Allow time for the system to stabilise. With no flow check that the flowmeter is reading zero, that the analog output is reading 4 mA, and that there is no pulse output.

The AC excitation version of the SAFMAG is inherently more susceptible to 50Hz noise. These signal converters have zero cut-off below 0.1m/s. If with no flow the flowmeter is indicating a flowrate, this indicates that excessive noise is being introduced via the signal cables and the screening / earthing. Should this occur, check the wiring!

Empty pipe detection is standard with the microprocessor signal converter. When the converter detects a high impedance in the electrode circuit, typically caused by an empty or partially filled pipe, an interrupt is sent to the microprocessor, which returns the flow reading to zero.

Although the empty pipe detection is standard, in some applications the conditions can create a situation where the flowmeter will still read intermittently, and **IT IS ESSENTIAL THAT FOR A TROUBLE FREE INSTALLATION THE METER BE FULL OF LIQUID AT ALL TIMES.**

SECTION 3 Calibration

3.1 Factory Calibration and programming

Before despatch the signal converter has been programmed, either to the factory standard or to those specifications advised by the customer. The SAFMAG electromagnetic flowmeter has been calibrated on the FLOWMETRIX calibration facility with direct trace ability to the National Standard. The unit will hold its stated accuracy indefinitely provided that it is correctly installed and undamaged.

FLOWMETRIX SA

SAFMAG Electromagnetic Flowmeter

3.2 Calibration Coefficient

Due to the design characteristics of the various SAFMAG flowmeters, each has its own calibration coefficient (k-factor). This coefficient is determined during the factory calibration, and will not change unless the flowtube is damaged.

3.3 Re-Calibration

The SAFMAG microprocessor signal converter has been designed for programming simplicity. The signal converters are interchangeable, and to re-calibrate a flowmeter the new parameters must be entered via the four push buttons.

All set-up requirements are contained in the menus, and each item is stepped to by pressing the **M** button. **NB The new data is only accepted if the 'save & exit' instruction is executed.**

Menu Organisation (SAFMAG DC Pulsed Version 5.10)

With the SAFMAG signal converter powered up flow total and flow rate are displayed

F→ 00000000 It
F→ 3.9768 l/s

F→ indicating Forward Flow and
R← indicating Reverse Flow

START - Press 'M'

Password?

Enter the required password. The flowmeter is shipped with the password 1000. (Default password = 1942). The signal converter set-up can be viewed without the password, however, no changes can be saved at the Save & exit menu and the error message "wrong password" is displayed.

Press ► repeatedly until cursor is under digit to be edited

Press ▲ repeatedly until desired value is displayed and **M** to continue

Change ?
1000

Providing the correct password was entered, a new password can now be entered. Enter the required password.

Press ► repeatedly until cursor is under digit to be edited

Press ▲ repeatedly until desired value is displayed

Press **M** to continue to the **Main Menu**

FLOWMETRIX SA

SAFMAG Electromagnetic Flowmeter

Main Menu

The Main Menu consists of **Menu-1**, **Menu-2**, **Menu-3**, **Save & exit** and **Cal mode** (Calibration Mode)

Press **M** repeatedly to scroll through the Main Menu and **E** to enter the displayed menu

Menu 1 Flow Data

Menu-1
M-cont E-enter

Press **E** to enter or **M** to continue

Menu 2 Tube Data

Menu-2
M-cont E-enter

Press **E** to enter or **M** to continue

Menu 3 Output Data

Menu-3
M-cont E-enter

Press **E** to enter or **M** to continue

Save & exit

M-cont E-enter

Press **E** to save and exit or **M** to continue

Calibration Mode

Cal mode
M-cont E-enter

This menu option is used in conjunction with the **SAFMAG CALIBRATOR**, and provides an indication of any error that may exist in the signal converter. The calibration procedure is supplied with the calibrator.

MENU-1 Flow Data

M1_1 rate units
 I/s

Press **▲** repeatedly until desired units are displayed and **M** to continue

M1_2 bi-dir?
 yes

Selection of Bi-directional flow measurement

Press **▲** to select **yes** or **no** and **M** to continue

M1_3 max flow→F
 100 I/s

Enter the maximum forward flow rate at which to output 20mA

Press **▶** repeatedly until cursor is under digit to be edited

Press **▲** repeatedly until desired value is displayed and **M** to continue

FLOWMETRIX SA

SAFMAG Electromagnetic Flowmeter

M1_4 max flow ←R
100 l/s

Enter the maximum reverse flow rate at which to output 20mA
Press ► repeatedly until cursor is under digit to be edited
Press ▲ repeatedly until desired value is displayed and **M** to continue

M1_5 total units
m3

Select the unit in which you wish to totalise
Press ▲ to select option required and **M** to continue

M1_6 total opts
fwd total

Note: Total flow display options are only available if bi-directional flow measurement is selected (see **M1_2**)

Select the total display option required
fwd total – forward flow total continuously displayed
rev total – reverse flow total continuously displayed
auto select – display automatically selected, forward total if there if forward flow and vice versa
toggle – display will toggle between forward and reverse flow totals
Press ▲ to select option required and **M** to continue

M1_7 clr total?
yes

Select **yes** to clear the existing flow total or **no** to keep existing flow total
Press ▲ to select option required and **M** to continue

M1_8 damping
0.25 Sec

0.25, 0.5, 1, 2.5, 5, 10, 20, & 40 second damping settings are available
Press ▲ to select option required and **M** to continue

M1_9 cutoff
2%

0%, 1%, 2%, 3%, 4%, 5% & 10% cutoff settings available
Select the level below which the signal converter will output no flow
Press ▲ to select option required and **M** to continue to **Main Menu**

Menu- 2 Flowtube Data

M2_1 tube type?
Mx - (ISO length)

Select tube type either Mx or Ms as stamped on the flowtube.
Press ▲ to select the tube type and **M** to continue

FLOWMETRIX SA

SAFMAG Electromagnetic Flowmeter

M2_2 dia mm
100.

Enter the nominal diameter of the flowmeter stamped on the flowtube.
Press ► repeatedly until cursor is under digit to be edited
Press ▲ repeatedly until desired value is displayed and **M** to continue

M2_3 K-value
1.023

Enter the calibration coefficient stamped on the flowtube
Press ► repeatedly until cursor is under digit to be edited
Press ▲ repeatedly until desired value is displayed and **M** to continue

M2_4 coil freq
3:3.125Hz

Enter the coil frequency stamped on the flowtube
Press ▲ repeatedly to select correct frequency and **M** to continue

M2_5 50/60Hz?
50Hz operation

Select the AC power supply frequency
Press ▲ to select and **M** to continue

Menu- 3 Output Data

M3_1 mA o/p
4-20 mA

0-20mA and 4-20mA Output available
Press ▲ to select the output required and **M** to continue

M3_2 set 20 mA
3800

Connect an accurate milliamp meter to the current output terminals
Select a value that drives the output to 20mA (approx. 3800)
Press ► repeatedly until cursor is under digit to be edited
Press ▲ repeatedly until desired value is displayed
Press **M** to continue

M3_3 sim % o/p
100.

The output current can be driven to any percentage of full scale by entering the desired value.
This facility can be used for testing the mA loop.
Press ► repeatedly until cursor is under digit to be edited
Press ▲ repeatedly until desired value is displayed and **M** to continue

FLOWMETRIX SA

SAFMAG Electromagnetic Flowmeter

M3_4 pulse o/p pulse

The function of the output pulse is selectable. If the 'pulse' option is selected, a 24V pulse is available at the pulse output terminals. This pulse rate is selectable via the options provided in Menu 3_6. If the reverse flow option is selected, the 24V pulse is only available with reverse flow.

Press **▲** to select the option and **M** to continue

M3_5 puls-width 20ms

The output pulse width can be varied.

Press **▲** repeatedly until the desired value is displayed and **M** to continue

N.B. the pulse output will change to a frequency with equal on-off period for a pulse rate >2.083Hz if the coil excitation frequency is 2.083Hz, or pulse rates >3.125Hz for any other coil excitation frequency.

M3_6 puls-opts. 1.00 pulse/unit

With "pulse" option selected in M3_4

0.01, 0.10 & 1.00 pulse/unit options are available where the units are those selected in Menu 1_5.

Press **▲** to select and **M** to continue

N.B. The count rate of the totaliser is limited to 100 counts/second. Above this count rate an error message is displayed.

FLOWMETRIX SA

SAFMAG Electromagnetic Flowmeter

SECTION 4 Servicing

4.1 Inspection and Maintenance

The SAFMAG electromagnetic flowmeter has no moving parts and therefore does not, under normal circumstances, require routine inspection or maintenance. Periodic inspection and cleaning of the meter body and electrodes will only be necessary if the fluid being measured forms deposits on the inside of the meter. If problems related to contamination, corrosion or erosion occur please contact your supplier or the factory. The SAFMAG solid state circuitry modular design and cast aluminium housing contribute to the high reliability of the SAFMAG system and the high MTBF.

4.2 Troubleshooting

Troubleshooting should be confined to establishing whether the fault lies in the flowtube assembly or in the electronics module.

The information provided should assist in this.

The flowtube coils have a resistance of approximately 20 ohms.

All DC pulsed meters are supplied with the coils connected in series, giving a measured value of 40 ohms at the terminals.

Large AC excited meters are supplied with the coils connected in parallel, giving a measured value of 10 ohms. If the coil resistance differs from these values, it indicates a fault in the measuring head.

Error Messages:

- “empty pipe” - Empty pipe detected ensure pipe is full at all times
- “count > 100” - Count rate too high for totaliser, choose a more appropriate totalising unit eg l to m³

FLOWMETRIX SA

SAFMAG Electromagnetic Flowmeter

TESTING OF FLOW TUBE

Always switch off power source before connecting and disconnecting cables.

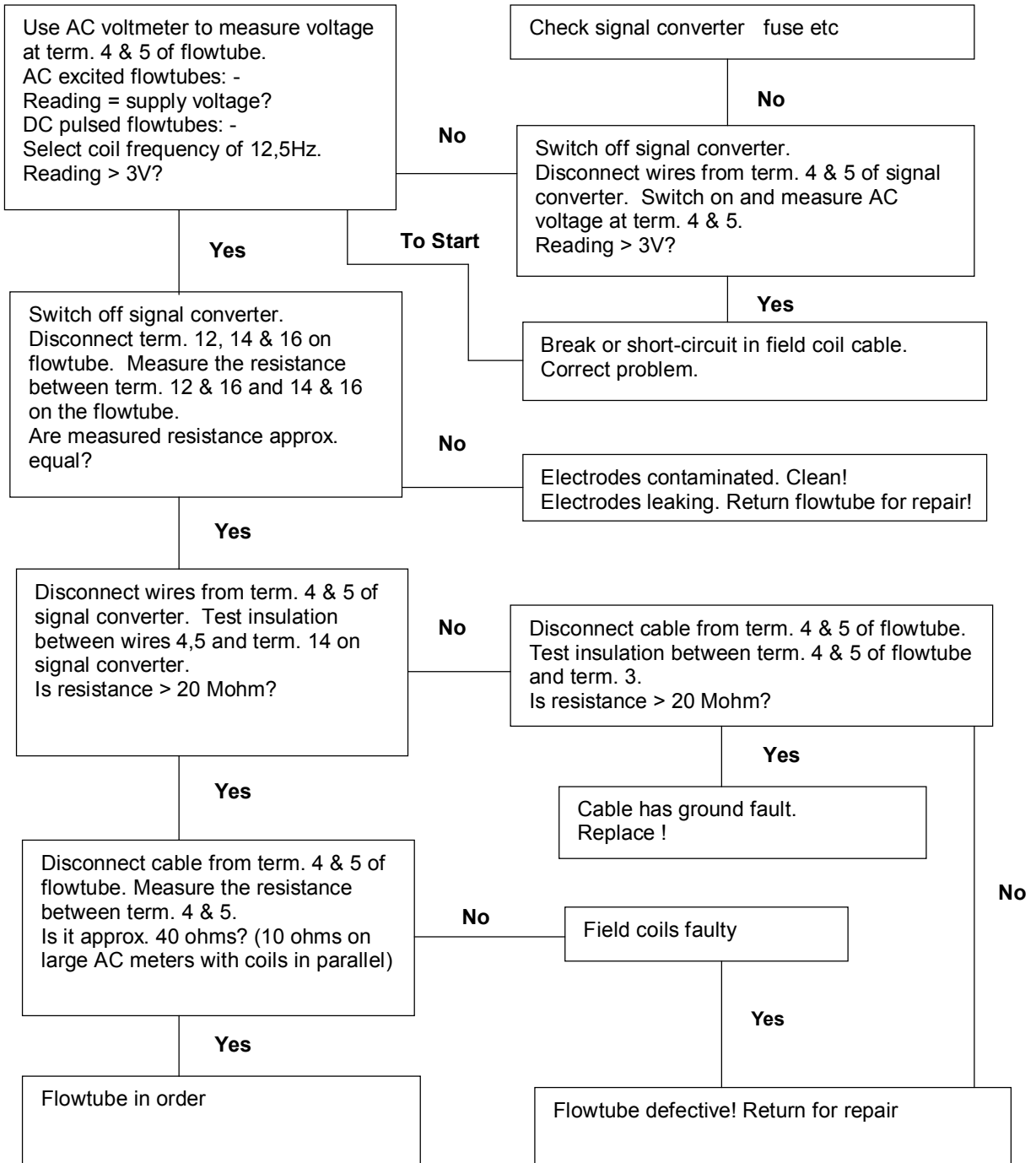

FLOWMETRIX SA

SAFMAG Electromagnetic Flowmeter

Testing (cont..)

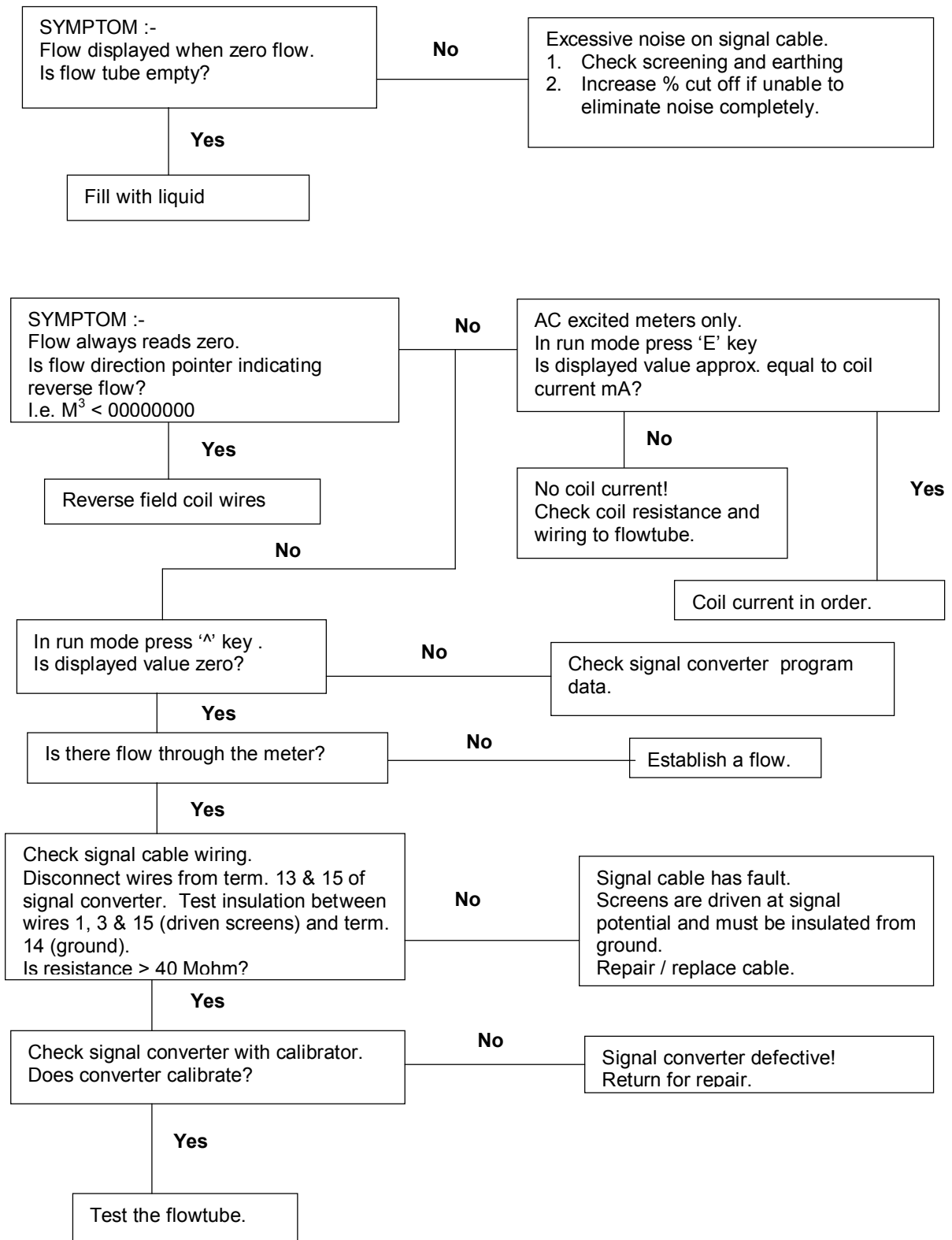

FLOWMETRIX SA

SAFMAG Electromagnetic Flowmeter

SECTION 5 Specifications

Performance specification

System specifications are stated at reference conditions with frequency output. The flowtube is calibrated against a reference DCMPU flowmeter.

Accuracy

Display and frequency output
 $\pm 0.5\%$ of rate for velocity $> 0.5\text{m/s}$
 $\pm 0.025\%$ of full scale for velocity $< 0.5\text{m/s}$

Analog output

above error plus $\pm 0.008\text{mA}$

Repeatability

$\pm 0.1\%$ of rate

Temperature effect

$\pm 0.01\%$ per deg. C

Mounting

Directly into pipeline at any attitude, ensuring that the flowtube remains completely full

Separation

Maximum recommended distance between the flowtube and the remote mounted signal converter is 100 metres

Sensor specification

The SAFMAG sensors are available in flanged and wafer format.

Sizes (nominal bore)

25mm to 900mm (flanged format)

40mm to 100mm (wafer format)

Process connections

Flat face steel flanges to mate with specified flange pattern (mild steel as standard)

Metering tube

304 stainless steel

Pressure

Maximum pressure dictated by flange rating 25mm to 150mm 1000kPa as std sizes $> 150\text{mm}$ 1600KPa as std for higher pressure consult factory

Electrodes: Non-removable

316 stainless steel, Hastelloy C, Monel (other - consult factory)

Earth electrode

Fitted as standard

Lining material (temperature limits)

Neoprene * -10 to 80 deg.C

Natural rubber * -10 to 70 deg.C

Polyurethane * -10 to 50 deg.C

Ebonite -10 to 95 deg.C

PTFE -20 to 150 deg.C

* flanged sensors only

Temperature

Sensors: refer to limitations of lining material

Sensors with integral transmitters:

Ambient: -10 to + 50 deg. C

Process fluid: -10 to + 70 deg. C,

but

refer to limitations of lining material

Environmental protection Sensors: IP68

Sensors with integral transmitter: IP65

Sensor housing

Rolled 3CR12 cover welded to steel side panels

Paint

Polyurethane acrylic enamel

Terminal box

Epoxy coated cast aluminium

(remote) Glass reinforced polyester

(integral)

Electrical connections (terminal

box) Two 20mm IP68 glands

FLOWMETRIX SA

SAFMAG Electromagnetic Flowmeter

Weights	
Size (mm)	Flowtube weight (kg)
25	10
40	12
50	20
65	22
80	23
100	27
125	30
150	42
200	60
250	80
300	100
350	140
400	190
450	220
500	280
600	420
700	500
750	560
800	650

Approximate values only - actual weights will vary dependent on the flange and pressure rating. Remote electronics weight 4 kg.

Signal converter specification

The DCMPU signal converters are available for remote mount or integral mount. ACMPU signal converters are available only as remote mounted units. Both are capable of processing signals from fluid velocities between 0.01 and 10.0m/s for all flowtube sizes. Full scale is adjustable between 1 and 10m/s.

Interchangeability

Converters are fully interchangeable with all sizes of flowmeters and configurable on site. A DCMPU converter must be replaced with another DCMPU and likewise for an ACMPU. Flowtubes are flow-calibrated and assigned a calibration factor at the factory. This calibration factor is entered into the converter, enabling interchangeability.

Conductivity

Process fluid must have a conductivity of at least 5 micro-siemens/cm.

Display

Flow total and flow rate are continuously displayed on the 2 - line backlit LCD display. Illuminated display on remote version only.

Power supply

115V or 230V ac \pm 10%, 50 or 60Hz
12 - 30V dc

Power consumption (tube plus signal converter)

20VA maximum - DCMPU
200VA maximum - ACMPU

Ambient temperature limits

-10 to +50 deg. C

Output signals

4 - 20mA into 1000 ohm load. (isolated output).
24V active pulse output to drive remote totaliser.

Analog output adjustment

Engineering units for flowrate are user selected.
Output scaled to provide 4mA at zero flow, 20mA at the selected maximum flow value.

Pulse width

Adjustable from 10ms to 500ms

Software lockout

Changes in configuration data protected by user entered password.

Output testing

Converter may be commanded to supply a specified output current.

Low flow cutoff

Adjustable. Below selected value outputs are driven to zero.

Damping

Adjustable between 0.25 and 40 seconds.

FLOWMETRIX SA

SAFMAG Electromagnetic Flowmeter

SECTION 6 Warranty

Flowmetrix SA CC warrants to the purchaser that the equipment to be delivered hereunder will be free from defects in materials, workmanship and title and will be of the kind and quality designated in the proposal.

The foregoing warranty is exclusive and in lieu of all other warranties whether express or implied including any warranty of merchantability or of fitness for a particular purpose.

Warranties other than the above will only be effective if written and signed by an officer of Flowmetrix SA CC

If within 1 (one) year from the date of installation or within 18 (eighteen) months of delivery to site, whichever first occurs, the equipment delivered hereunder does not meet the warranties specified above, Flowmetrix SA CC shall thereupon correct such defects, at its sole discretion, either by repairing or by replacing the instrument in its entirety.

The costs of returning the equipment to Flowmetrix SA CC and for the repaired or replaced item being returned to the purchaser shall be for the account of the purchaser.

The liability of Flowmetrix SA CC is conditioned upon the equipment covered hereunder being handled, installed, operated, maintained, stored or used, as the case may be, in strict accordance with the written instructions or technical direction supplied by Flowmetrix SA CC, and is further conditioned upon the purchasers prompt written notice (within 30 days) to Flowmetrix SA CC of such defects.

Flowmetrix SA CC makes no warranties which extend to the items covered hereby due to improper handling, installation, operation, maintenance, storage or use; abnormal or undisclosed environmental conditions; or operating or use in an otherwise improper manner.

The conditions of any test shall be mutually agreed upon, and Flowmetrix SA CC shall be notified of, and may be represented at all tests that may be made.

The liability of Flowmetrix SA CC to the purchaser, except as to title, arising out of the supplying of the equipment or its use, under this warranty article, shall not, in any case, exceed the cost of correcting defects in the equipment as herein provided and upon the expiration of the warranty described herein, all such warranty liability shall terminate. The foregoing shall constitute sole warranty remedy of the purchaser and the sole warranty liability of Flowmetrix SA CC.