

CABLE EXTENSION

Should it be necessary to extend the cable, KAB Instruments only recommend RG62U co-axial cable. The connection should be SOLDERED and connected as below.

The transducer cable to RG62U cable



The red cable from the transducer is soldered to the single conductor on the RG62U cable and the black and screen from the transducer are connected to the screen of the RG62U co-axial cable.

RG62U cable and input connection on the instrument

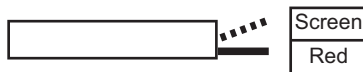

The other end of the RG62U cable should be connected to the transducer connection with the single conductor going to the red marked terminal and the screen going to the SCR marked terminal.

The extra length of cable should not exceed 250m. This distance could be shorter if the cable is run close to high voltage cables.

CONTENTS

Declaration of conformity	2
Warranty	2
Introduction	3
Quick start	3
Changing parameters	4
Specifications	
• Transmitter	6
• Transducer	7
Installation	
• Transmitter	8
• Transducer	9
• Temperature sensor	11
Key description	12
Security code	12
Configuration	13
Examples	
• V-Notch	19
• Rectangular Weir	21
• Parshall Flume	23
• Venturi Flume	25
Fault Finding	27
Terminal Connections	29
Dimensions	
• Transmitter	30
• Transducers	31
Cable extension	32

Copyright (c) 1994....2001 by KAB Instruments (Pty) Ltd. All rights reserved.
No part of this manual may be reproduced by hard-copy, electronic or computerised copy or any other copy method.

DECLARATION OF CONFORMITY

SUMPI FM complies with conformity in accordance with the following tests.

Electromagnetic Compatibility

Susceptibility:	EN50082-1	EN801-2,3,4,	ENV50204
	EN50082-2	ENV50140	
Emission:		EN61000-4-2	ENV50141
	EN 50081-2	EN 55011	
	EN 50081-1	EN55022	EN60555-2,3

Safety: BSEN61010-1

CE Conformity Declaration

SUMPI FM is in accordance with EN50081-2 1993 and EN 50082-2 1995.

Johannesburg, South Africa, 3rd June 1999.

Kevin Barnfather

Kevin Barnfather
KAB Instruments (Pty) Ltd

WARRANTY

KAB Instruments (Pty) Ltd's products will be replaced, repaired, put in good operating condition, or the purchase price refunded, at the option of KAB Instruments, free of charges except transportation, if defective in their manufacture, and if notice of the said defect is received by KAB within one year from date of delivery. The cost of such replacement, repair or refund of purchase price shall be the exclusive remedy for any breach of warranty, and KAB shall not be liable to any person for consequential damages for injury or commercial loss resulting from any breach of warranty. KAB makes no warranty of fitness for a particular purpose, and makes no other warranty, express or implied, including implied warranty arising from course of dealing or usage of trade.

DIMENSIONS

Transducer KAB 10 / KAB 10C

Application, general use non-corrosive liquid.

KAB 10C has 2 extra wires. Blue and white for temperature compensation.

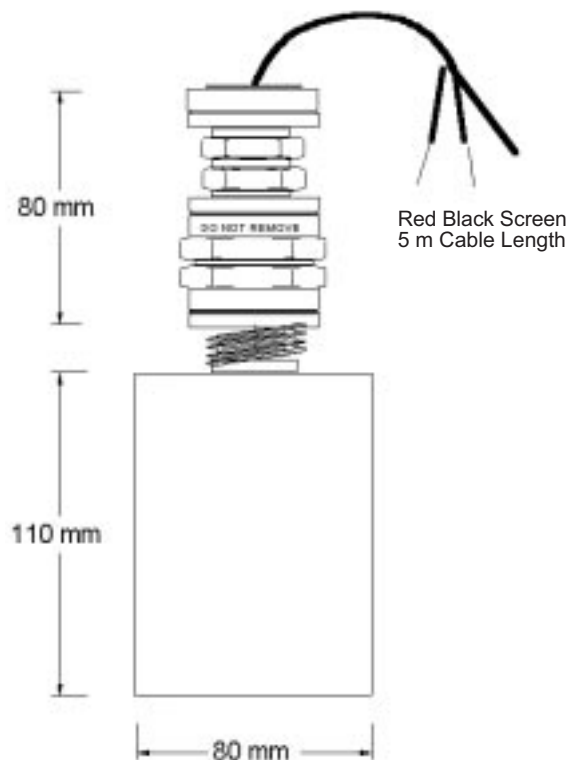

DIMENSIONS

Transmitter

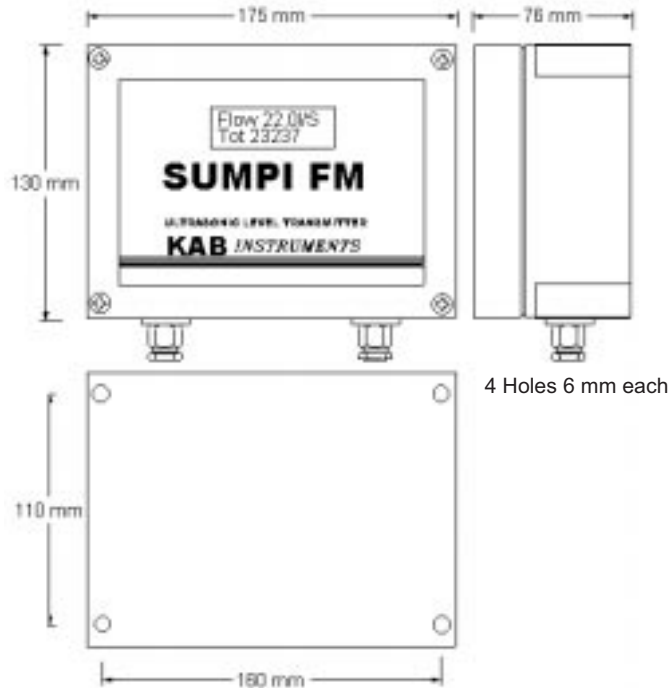

INTRODUCTION

SUMPI FM works on the non-contact principle of ultrasonics.

A pulse of energy emits from the Transducer at the speed of sound and is detected upon its return. The Transmitter can distinguish the difference between the correct echo and other ambient noise.

When the signal returns, SUMPI FM measures the time period, and then knowing the speed of sound, it can accurately calculate the distance from the material to the Transducer. This is then converted into a flow rate.

A microprocessor then controls the output functions of the relays, display and the analogue output signal.

QUICK START

SUMPI FM was designed with a very simple configuration program. This allows the technician to set up SUMPI FM without the aid of a complicated source-code book. There are no references to any codes in SUMPI FM. The set up procedure is all menu driven with the aid of questions and multiple-choice answers.

Connect up the mains and the Transducer connections as described on the SUMPI FM board or in the SUMPI FM manual.

PLEASE NOTE! ALL CONNECTIONS ARE CAPABLE OF BEING UNPLUGGED FROM THE PCB.

Aim the Transducer at a wall about 1.5 meters away and check the display. It should read the following.

```
FL = 60.13lt/Sec
Tot 346568
```

If you press ENTER the FL (FLOW) reading will change to the head height as below.

```
Hd = 500mm
Tot 3457668
```

If the reading is below 500mm then move the transducer closer to the wall. If the reading is above 500mm then move the transducer away from the wall. You may now proceed and check other distances. PLEASE NOTE the Totaliser should be counting.

CHANGING PARAMETERS

Step 1

Simply press SCROLL until the SECURITY CODE prompt is displayed.

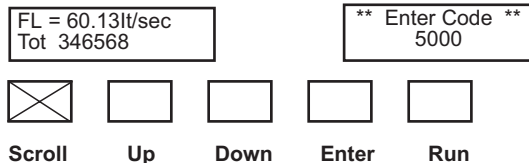

Step 2

Enter the code 5159 by pressing the UP and DOWN keys.

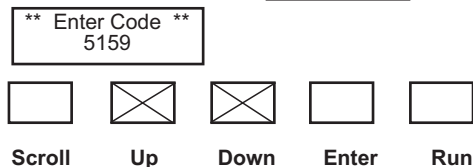

Step 3

Press ENTER.

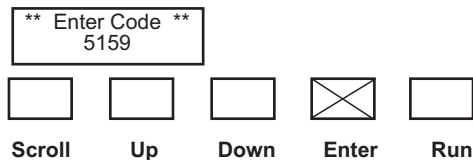

Code has been accepted.

Select mm/inch mm

TERMINAL CONNECTIONS

DIMENSIONS

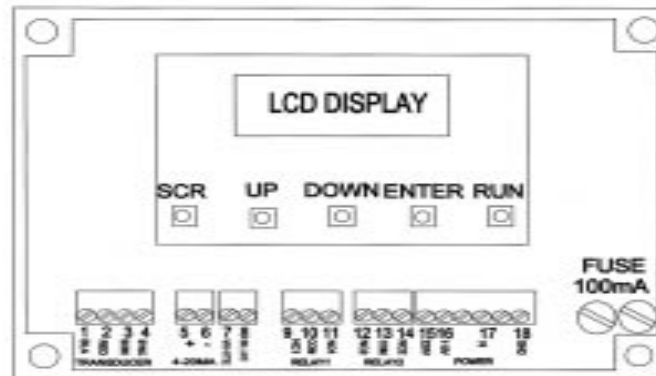

AC POWER SUPPLY

1. Transducer black
2. Transducer red
3. Transducer screen
4. Not used
5. 4-20mA output positive
6. 4-20mA output negative
7. Temperature probe white
8. Temperature probe blue
9. Relay 1 normally closed
10. Relay 1 common
11. Relay 1 normally open
12. Relay 2 normally closed
13. Relay 2 common
14. Relay 2 normally open
15. Power supply 220v live
16. Power supply 110v live
17. Power supply neutral
18. Ground

DC POWER SUPPLY

1. Transducer black
2. Transducer red
3. Transducer screen
4. Not used
5. 4-20mA output positive
6. 4-20mA output negative
7. Temperature probe white
8. Temperature probe blue
9. Relay 1 normally closed
10. Relay 1 common
11. Relay 1 normally open
12. Relay 2 normally closed
13. Relay 2 common
14. Relay 2 normally open
15. Power supply 24VDC
16. Power supply 0VDC

Please see page 32 if extension cable is used

Wrong reading, always reading close to Transducer.

Check to see if the isolation kit has been used correctly and is only hand tight.

Do not reduce blanking distance below 0.5 m unless consultation has been made with KAB Instruments.

Electrical noise can cause this error. Remove noise.

Wrong reading, anywhere in weir/channel.

Check to see if there is a reflection from the wall.

Please Note! A piece of wire across a tank can cause a big enough echo to be accepted.

Are the parameters correct? Reset to factory default and check that SUMPI FM reads correctly. If the factory settings are OK then your parameters need to be changed. Re-check these parameters with a tape measure.

Wrong reading, erratic.

Reduce Rate of Change. Not many levels move faster than 1 meter / minute.

Wrong reading, slow.

Increase Rate of Change.

Code not accepted, please try again.

FL = 60.13lt/sec Tot 346568

The display will indicate that it has accepted the code by requesting the application, either mm or inch.

If you would like to carry on programming, the configuration list is on page 13.

SPECIFICATIONS

Transmitter

Enclosure

- Polycarbonate
- Rated at IP65

Power supply

- 220 VAC or 110 VAC
- 24 VDC

Power consumption

- Transmitter 3 VA

Dimensions

- 130 mm x 175 mm x 76 mm

Weight

- 1.5 kg

Temperature

- -30°C to 65°C

Operating frequency

- 42 kHz

Range

- 10 m

Accuracy

- +/- 0.25% with add on temperature probe

Indication

- 2 x 16 alpha numeric display

Fail-safe analogue

- 2 mA, 4 mA, 20mA, 22mA, or Hold value

Configuration

- 5 touch button keys

Blanking distance

- Min. 0.35 m

Rate of change

- 100 to 10000mm/ min.

Analogue output

- 4-20 mA max, Impedance 750 ohms, Isolated

Digital output

- 2 x 8 Amp SPDT 220VAC Relays

FAULT FINDING

There are three categories of possible faults. The malfunction of the instrument, loss of echo, and wrong reading.

The biggest problem is to identify the malfunction. If the instrument is not working satisfactorily then remove the transmitter and transducer to the workshop. Connect the power and the transducer directly, not using any extension cable. Aim the transducer to a wall about 1.5m meters away, making sure that it is perpendicular to the wall. Now reset the instrument by the Factory Reset prompt. The Instrument should now read Distance 1.50 m. If it does not read the above then there is a malfunction with the instrument and it should be returned for repair.

If the above works and it still does not work in the field then there are many possible problems. A list of possible problems follow.

Loss of echo.

Check all cable connections and that the joints are soldered together.

Use only RG62U co-axial.

Check the specification of the transducers as agitated surfaces and solids do not reflect as powerful a signal as flat surfaces.

Aim the transducer straight down.

Check if the Transducer face is dirty.

PARAMETER LIST

SECURITY CODE	5159
SELECT	mm
EMPTY DISTANCE	1200mm
SPAN	600mm
BLANKING	600mm
RATE OF CHANGE	1000 mm/min
FAIL TIMER	300
FAILSAFE MODE	Hold
FLOW CURVE	Venturi
FLOW UNITS	G/min
MAXIMUM FLOW	1435
SET UP RELAYS	Yes
RELAY 1	Counter
RELAY 2	High
RELAY 1 COUNTER	10000
RELAY 2 HIGH	500
RELAY 2 RESET	490
TOTALISER RESET	No
ZERO OFFSET	No
OFFSET	0
USE TEMP COMP	No
SET NEW PASSWORD	No
FACTORY RESET	No

Below is what SUMPI FM will display on the above application.

FI = 750 G/min
TI 2345665

and

Head 450mm
TI 2345665

Now the display will toggle when the ENTER key is pressed. The relay will drive the counter for every 10000 counts.

The analogue output should be approximately 19.1 mA.

SPECIFICATIONS

Transducer

KAB 10
Application -
Non-corrosive liquids.

Maximum range

- Liquid 10m

Beam angle

- 10 deg

Face material

- Polyurethane

Body material

- UPVC

Temperature range

- -20 to +80°C

Protection

- IP68

Mounting

- 1 inch BSP

Min blanking

- Under ideal conditions 0.3m

KAB 10C
Application -
Non-corrosive liquids with
Temperature Compensation

Maximum range

- Liquid 10m

Beam angle

- 10 deg

Face material

- Polyurethane

Body material

- UPVC

Temperature range

- -20 to +80°C

Protection

- IP68

Mounting

- 1 inch BSP

Min blanking

- Under ideal conditions 0.3m

Temperature compensation

- Built-in temperature compensation

INSTALLATION

Transmitter

The Transmitter is weather proof so it can be mounted outside. Although SUMPI FM is protected to IP65 it is recommended that it be installed inside another suitable enclosure.

The LCD display should not be facing full sunlight as this can cause the display to fail. SUMPI FM should be fixed to a wall or chassis plate using the four holes provided.

Do not install SUMPI FM in areas of high vibration as this may cause failure.

Do not install SUMPI FM in the close vicinity of electrical cable, SCR's or variable speed drives.

EXAMPLES

Venturi flume

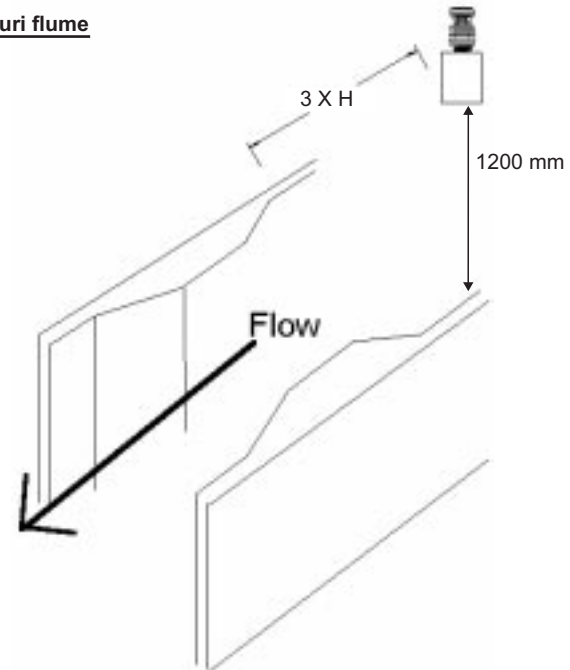

This is an example of a Venturi Flume application. The transducer is mounted 1200mm above the base of the flume, this is the Empty Distance. The Span is 600mm and the Blanking Distance is 600mm (min is 350mm). The transducer must be fitted 3 x head upstream. There is an external counter connected to the relay counter.

The water flow must not dam up and cause a build-up inside the flume. Please Note! The Empty Distance is to the bottom of the plate and not the bottom of the weir.

PARAMETER LIST

SECURITY CODE	5159
SELECT	mm
EMPTY DISTANCE	1200mm
SPAN	600mm
BLANKING	600mm
RATE OF CHANGE	1000 mm/min
FAIL TIMER	300
FAILSAFE MODE	Hold
FLOW CURVE	12 Inch Parshall
FLOW UNITS	G/min
MAXIMUM FLOW	1435
SET UP RELAYS	Yes
RELAY 1	Counter
RELAY 2	High
RELAY 1 COUNTER	10000
RELAY 2 HIGH	500
RELAY 2 RESET	490
TOTALISER RESET	No
ZERO OFFSET	No
OFFSET	0
USE TEMP COMP	No
SET NEW PASSWORD	No
FACTORY RESET	No

Below is what SUMPI FM will display on the above application.

FI = 600 G/min
TI 2345665

and

Head mm
TI 2345665

Now the display will toggle when the ENTER key is pressed. The relay will drive the counter for every 10000 counts.

The analogue output should be approximately 19.1 mA.

INSTALLATION

Transducer

The installation of the Transducer is the most important section of this manual and has been divided up into 5 sub sections.

1. The Transducer must be fitted at least 0.35m above the highest point of flow.
2. Always use the plastic isolation kit. This kit must be fitted to a rigid support and must not be allowed to swing in a breeze. Use mild steel or a suitable plastic. Do not use stainless steel as this can cause ringing.

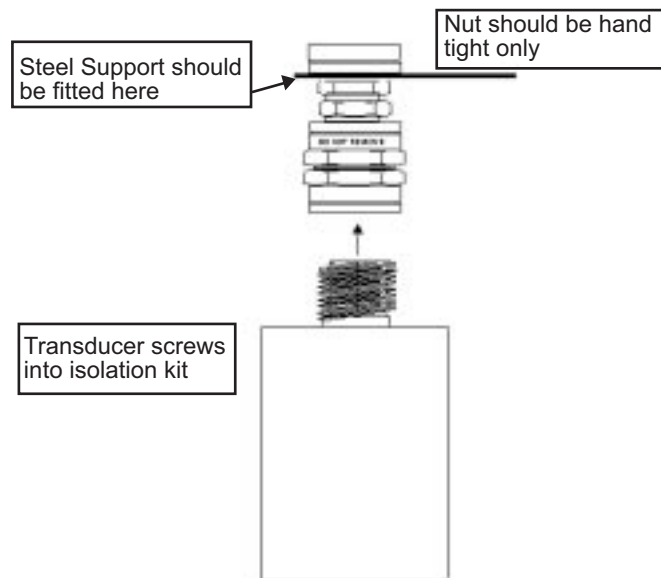

3. The Transducer must be perpendicular to the water flow it is measuring with a clear line of sight and must not be above beams or filling points.
4. If any large electrical equipment is installed in the vicinity, then earthed steel conduit must be used.
5. An extension of up to 250m using RG62U cable is possible. All connections must be soldered together. It is advisable to install the Transducer cable inside steel conduit, especially if large electrical spikes (interference) are present.

EXAMPLES

Parshall flume

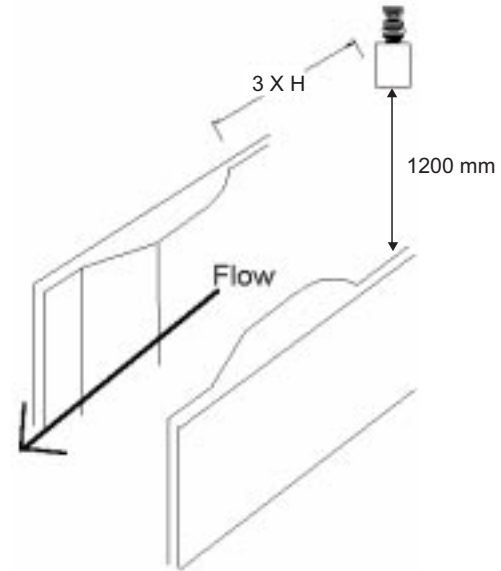

This is an example of a 12 inch Parshall Flume application. The transducer is mounted 1200mm above the base of the flume, this is the Empty Distance. The Span is 600mm and the Blanking Distance is 600mm (min is 350mm). The transducer must be fitted 3 x head upstream. There is an external counter connected to the relay counter. The water flow must not dam up and cause a build up inside the flume. Please Note! The Empty Distance is to the bottom of the flume and not the bottom of the channel.

PARAMETER LIST

SECURITY CODE SELECT	5159
EMPTY DISTANCE	mm
SPAN	1000mm
BLANKING	600mm
RATE OF CHANGE	400mm
FAIL TIMER	1000mm/min
FAILSAFE MODE	300
FLOW CURVE	Hold
FLOW UNITS	Yes
MAXIMUM FLOW	Rectangle weir
SET UP RELAYS	M3/hour
RELAY 1	145
RELAY 2	Yes
RELAY 1 COUNTER	Counter
RELAY 2 HIGH	High
RELAY 2 RESET	10000
TOTALISER RESET	500
ZERO OFFSET	490
OFFSET	No
USE TEMP COMP	No
SET NEW PASSWORD	0
FACTORY RESET	No

Below is what SUMPI FM will display on the above application.

FI = 750 m3/Hr TI 2345665

and

Head 1000mm TI 2345665

Now the display will toggle when the ENTER key is pressed. The relay will drive the counter for every 10000 counts.

The analogue output should be approximately 19.1 mA.

INSTALLATION

Temperature Sensor

If there is a large change in temperature, a temperature sensor should be used. The error in level due to the change in temperature is 0.17% / deg'C. The Temperature sensor can be connected to the Transmitter via a 2 core overall screened cable.

Please note that the Temperature sensor is being used to measure the ambient air temperature and not the liquid temperature.

Do not mount the Temperature sensor in direct sunlight as this will increase the temperature reading.

KEY DESCRIPTION

SUMPI FM is "user friendly" having only 5 keys and a menu driven display. The keys are listed below with their appropriate functions.

SCROLL

This is used to initially access the programming mode and then to run through the various menus.



This key is used to INCREASE value in the various commands.



This key is used to DECREASE value in the various commands.

ENTER

When the value has been selected it can be accepted by pressing the ENTER key.

RUN

When programming is complete, press RUN to return SUMPI FM back to the run mode.

SECURITY CODE

To advance to the programming mode the correct security code must be entered. The factory default code is 5159. The code can be changed in the programming mode.

EXAMPLES

Rectangular Weir

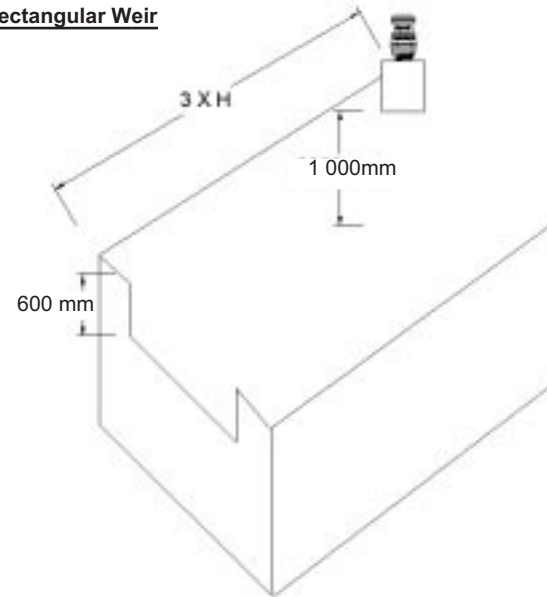

This is an example of a Rectangular weir application. The transducer is mounted 1000mm above the bottom of the rectangular weir, this is the Empty Distance. The Span is 600mm and the Blanking Distance is 400mm (min is 350mm). The transducer must be fitted 3 x head upstream. There is an external counter connected to the relay counter. The water flow must not dam up and cause a build up behind the weir. Please note! The Empty Distance is to the bottom of the plate and not the bottom of the weir.

PARAMETER LIST

SECURITY CODE	5159
SELECT	mm
EMPTY DISTANCE	2000mm
SPAN	1500mm
BLANKING	500mm
RATE OF CHANGE	1000mm/min
FAIL TIMER	300
FAILSAFE MODE	Hold
FLOW CURVE	V-notch
FLOW UNITS	Lt/sec
MAXIMUM FLOW	1222
SET UP RELAYS	Yes
RELAY 1	Counter
RELAY 2	High
RELAY 1 COUNTER	10000
RELAY 2 HIGH	1450
RELAY 2 RESET	1350
TOTALISER RESET	No
ZERO OFFSET	No
OFFSET	0
USE TEMP COMP	No
SET NEW PASSWORD	No
FACTORY RESET	No

Below is what SUMPI FM will display on the above application.

FI = 750 Lt/sec TI 2345665

and

Head 1000mm TI 2345665

Now the display will toggle when the ENTER key is pressed. The relay will drive the counter for every 10000 counts.

The analogue output should be approximately 19.1 mA.

CONFIGURATION

BASIC	OPTIONS	DEFAULTS	USER LIST
SECURITY CODE	0-9999	5159	
SELECT	mm/inch	mm	
EMPTY DISTANCE	300/1000	2000	
SPAN	100-9700	1500	
BLANKING	300-9700	500	
RATE OF CHANGE	100-1000	500	
ECHO LOSS TIMER	30-3000	300	
ECHO LOSS MODE	2,4,20,22, HOLD	NO	
FLOW CURVE*	SEE LIST	V-NOTCH	
FLOW UNITS**	SEE LIST	LT/SEC	
MAXIMUM FLOW	1-10000	1000	
SET UP RELAYS	ON-OFF	OFF	
RELAY 1	COUNT/LO/HI	COUNT	
RELAY 2	COUNT/LO/HI	COUNT	
RELAY 1 COUNTER	1000/60000	1000***	
RELAY 2 COUNTER	1000/60000	1000***	
RELAY 2 HIGH/LOW	1-10000	0	
RELAY 1 RESET	1-10000	0	
RELAY 2 HIGH/LOW	1-10000	0	
RELAY 2 RESET	1-10000	0	
TOTALISER RESET	YES-NO	NO	
ZERO OFFSET	YES-NO	NO	
OFFSET	+50/-50	0	
USE TEMP COMP	YES-NO	NO	
SET NEW PASSWORD	YES-NO	NO	
FACTORY RESET	YES-NO	NO	

***PLEASE NOTE**

The following weirs and flumes can be selected
 V notch
 Venturi flume
 Parshall flumes from 1 inch to 96 inch
 Own curve (Lineariser)

****PLEASE NOTE**

The following units can be selected
 Lt/sec, Lt/min, Lt/hr, or Lt/day
 g/sec, g/min, g/hr, or mg/day
 m3/sec, m3/min, m3/hr, or m3/day
 Q/sec, Q/min, Ft3/hr, or Q/day

*****PLEASE NOTE**

The counter rate cannot be selected below the flow rate setting.

SECURITY CODE

Security code to advance to programming.
 DEFAULT 5159

SELECT

Choose between mm and inch.
 DEFAULT mm

EMPTY DISTANCE

This is the distance from the face of the Transducer to the bottom of the flume.
 DEFAULT 2000mm

SPAN

This figure is the measuring range of the instrument i.e. distance from the bottom of the flume to the highest point being measured. Remember, the material must not approach within 0.35 meters of the Transducer face.
 DEFAULT 1500mm

BLANKING

This is the area where an echo cannot be processed because the return echo would be received whilst the Transducer is still firing.
 DEFAULT 500mm

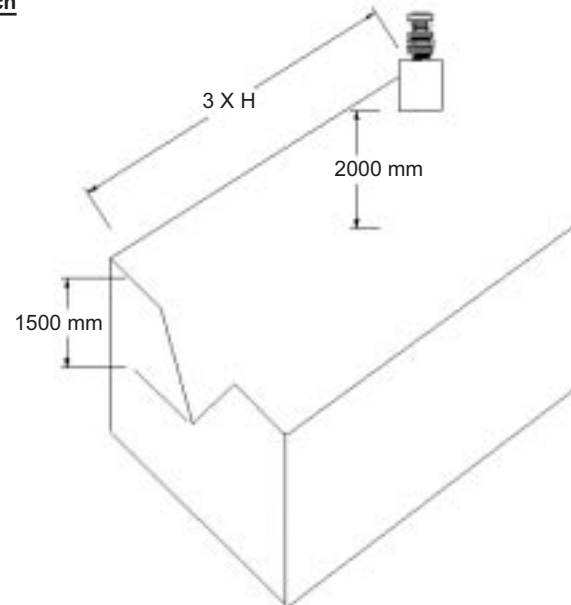
EXAMPLES**V-Notch**

This is an example of a V-Notch application. The transducer is mounted 2000mm above the Notch in the V, this is the Empty Distance. The Span is 1500mm and the Blanking Distance is 500mm (min is 350mm). The transducer must be fitted 3 x head-height upstream. There is an external counter connected to the relay counter. The water flow must not dam up and cause a build-up behind the weir. Please Note! The Empty Distance is to the bottom of the plate and not the bottom of the weir.

USE TEMPERATURE COMPENSATION

Select Yes only if a KAB10C is used or a Temperature Transducer is connected.
DEFAULT No

SET NEW PASSWORD

This prompt will allow you to change the default factory password.
DEFAULT No

FACTORY RESET

This prompt will reset all values entered back to factory settings including the password. Please write down all settings before using this function.
DEFAULT No

RATE OF CHANGE

This is used to set up the rate of change of the level output. Increase the number if the level moves faster than 500mm / minute and decrease it if a more stable output is required.
DEFAULT 500mm/min

ECHO LOSS TIMER

This is the amount of time between last receiving a correct echo and going into the below Fail-safe condition. This time period is timed in seconds.
DEFAULT 300Sec

ECHO LOSS MODE

If a loss of echo condition is reached then the 4-20mA output will follow the configured settings 2mA, 4mA, 20mA, 22mA or hold the last recognised echo. This is usually due to a cable being cut or the above not being set up correctly.
DEFAULT Hold

FLOW CURVE

The flow element can be selected here. Find the choices below.
V-notch weir (5/2) any angle can be used here.
Venturi (3/2)
Parshall flume 1 to 96 Inch
Rectangular weir (3/2)
Own curve (21 point lineariser)
DEFAULT V-Notch

LINEARISER (only available if Own curve is selected above)

This prompt allows you to set up a flume that is not in the above list. First make a graph with 21 points and enter each point at 5% intervals. The span is divided into 21 points and then you can select the percentage flow at these points.
DEFAULT No

MAXIMUM FLOW

This prompt allows you to select the maximum flow rate so the instrument can compute the flow rate.

DEFAULT 1000

SET UP RELAYS

The relays MUST be switched on here to set them up.

DEFAULT Off

RELAY 1

The relays can be used either for an external counter, high alarm or a low alarm. The difference is that a high alarm has its reset below the setpoint, and a low alarm has its reset above the setpoint.

DEFAULT Off

RELAY 2

As above.

DEFAULT Off

COUNTER 1

The external counter or sampler can be set here. Select the amount of counts before the sampler will be activated.

DEFAULT 1000

RELAY 1 HIGH or LOW depending upon selection

This is the setting for the High or the Low alarm depending on which is selected.

DEFAULT 0.00mm

RELAY 1 RESET

This is where you can enter the reset. Please note that if it is a high alarm then the reset must be below and if it is a low alarm then the reset must be above the setting.

DEFAULT 0.00mm

RELAY 2 HIGH or LOW depending upon selection

As above.

DEFAULT 0.00mm

RELAY 2 RESET

As above.

DEFAULT 0.00mm

TOTALISER RESET

The totaliser can be reset here.

DEFAULT No

ZERO OFFSET

Should there be a small offset at the Zero this prompt can be used to offset it.

DEFAULT No

OFFSET

Up to a maximum of 50 mm minus and positive.

DEFAULT 0mm