

CONTENTS

Declaration of conformity	2
Warranty	2
Introduction	3
Quick start	3
Changing parameters	4
Specifications	
● Transmitter	6
● Transducer	7
Installation	
● Transmitter	10
● Transducer	11
● Temperature sensor	14
Key description	15
Security code	15
Configuration	16
Examples	
● Distance	22
● Level	23
Fault finding	27
Terminal connections	29
Dimensions	
● Transmitter	30
● Transducers	31
● Aiming kit	35
Cable extension	36
KABScope	37

Copyright (c) 1994....2001 by KAB Instruments (Pty) Ltd. All rights reserved.
No part of this manual may be reproduced by hard-copy, electronic or
computerised copy or any other copy method.

DECLARATION OF CONFORMITY

SUMPI complies with conformity in accordance with the following tests.

Electromagnetic Compatibility

Susceptibility:	EN50082-1	EN801-2,3,4,	
	EN50082-2	ENV50140	ENV50204
		EN61000-4-2	ENV50141
		EN61000-4-4	
Emission:	EN 50081-2	EN 55011	
	EN 50081-1	EN55022	EN60555-2,3

Safety: BSEN61010-1

CE Conformity Declaration

SUMPI is in accordance with EN50081-2 1993 and EN 50082-2 1995.

Johannesburg, South Africa, 3rd June 1999.

Kevin Barnfather

Kevin Barnfather
KAB Instruments (Pty) Ltd

WARRANTY

KAB Instruments (Pty) Ltd's products will be replaced, repaired, put in good operating condition, or the purchase price refunded, at the option of KAB Instruments, free of charges except transportation, if defective in their manufacture, and if notice of the said defect is received by KAB within one year from date of delivery. The cost of such replacement, repair or refund of purchase price shall be the exclusive remedy for any breach of warranty, and KAB shall not be liable to any person for consequential damages for injury or commercial loss resulting from any breach of warranty. KAB makes no warranty of fitness for a particular purpose, and makes no other warranty, express or implied, including implied warranty arising from course of dealing or usage of trade.

INTRODUCTION

SUMPI works on the non-contact principle of ultrasonics.

A pulse of energy emits from the Transducer at the speed of sound and is detected upon its return. The Transmitter can distinguish the difference between the correct echo and other ambient noise.

When the signal returns, SUMPI measures the time period, and then knowing the speed of sound, it can accurately calculate the distance from the material to the Transducer.

A microprocessor then controls the output functions of the relays, display and the analogue output signal.

QUICK START

SUMPI was designed with a very simple configuration program. This allows the technician to set up SUMPI without the aid of a complicated source-code book. There are no references to any codes in SUMPI. The set up procedure is all menu driven with the aid of questions and multiple-choice answers.

Connect up the mains and the Transducer connections as described on the SUMPI board or in the SUMPI manual.

PLEASE NOTE! ALL CONNECTIONS ARE CAPABLE OF BEING UNPLUGGED FROM THE PCB.

Aim the Transducer at a wall about 2 meters away and check the display. It should read the following.

Dist = 2.00m Relays DISABLED

If the reading is above 2.00m then move the transducer closer to the wall.
If the reading is below 2.00m then move the transducer away from the wall.
You may now proceed and check other distances.

CHANGING PARAMETERS

Step 1

Simply press SCROLL until the SECURITY CODE prompt is displayed.

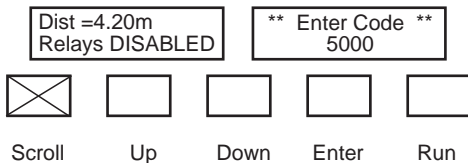
**Step 2**

Enter the code 5159 by pressing the UP and DOWN keys.

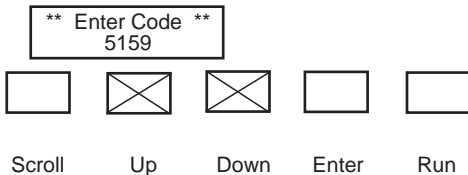
**Step 3**

Press ENTER.

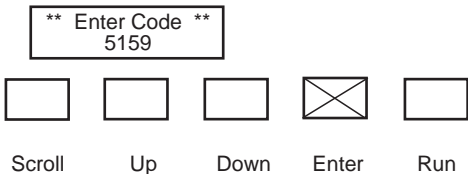

Code has been accepted.

Operation Mode
Distance

Code not accepted, please try again.

Dist =4.20m
Relays DISABLED

The display will indicate that it has accepted the code by requesting the application, either level or distance.

If you would like to carry on programming, the configuration list is on page 16.

SPECIFICATIONS

Transmitter

Enclosure

- Polycarbonate
- Rated at IP65

Power supply

- 220 VAC or 110 VAC
- 24 VDC

Power consumption

- Transmitter 3 VA

Dimensions

- 130 mm x 175 mm x 76 mm

Weight

- 1.5 kg

Temperature

- -30°C to 65°C

Operating frequency

- 42 kHz

Range

- 10 m on liquids and solids depending on transducer

Accuracy

- +/- 0.25% with add on temperature probe

Indication

- 2 x 16 alpha numeric display

Fail-safe analogue

- 2 mA, 4 mA, 20mA, 22mA, or hold value

Configuration

- 5 touch button keys

Blanking distance

- Min. 0.5 m for KAB 10 Transducer, 0.3 m on request.

Rate of change

- 0.1 to 10 m/min.

Analogue output

- 4-20 mA max, Impedance 750 ohms, Isolated

Digital output

- 2 x 8 Amp SPDT 220VAC Relays

SPECIFICATIONS

Transducer

KAB 10	KAB 10C
Application, non-corrosive liquids.	Application, non-corrosive liquids with Temperature Compensation
Maximum range	Maximum range
● Liquid 10m	● Liquid 10m
Beam angle	Beam angle
● 10 deg	● 10 deg
Face material	Face material
● Polyurethane	● Polyurethane
Body material	Body material
● UPVC	● UPVC
Temperature range	Temperature range
● -20 to +80°C	● -20 to +80°C
Protection	Protection
● IP68	● IP68
Mounting	Mounting
● 1 inch BSP	● 1 inch BSP
Min blanking	Min blanking
● Under ideal conditions 0.3m	● Under ideal conditions 0.3m
	Temperature compensation
	● Built in temperature compensation

KAB 10F**Application, dusty solids.**

Maximum range

- Solid 10m

Beam angle

- 10 deg

Face material

- Polyurethane foam

Body material

- UPVC

Temperature range

- -20 to +80°C

Protection

- IP64

Mounting

- 1 inch BSP

Min blanking

- Under ideal conditions 0.3m

KAB 10T**Application, Stand pipe.**

Maximum range

- Liquid 10m

Beam angle

- 10 deg

Face material

- Polyurethane

Body material

- UPVC

Temperature range

- -20 to +80°C

Protection

- IP68

Mounting

- 3 inch or 4 inch flange, ANSI 150

Min blanking

- Under ideal conditions 0.3m

KAB 10T**PTFE LINED****Application, corrosive liquids.**

Maximum range

- Liquid 10m

Beam angle

- 10 deg

Face material

- PTFE

Body material

- UPVC

Temperature range

- -20 to +80°C

Protection

- IP68

Mounting

- 3 inch or 4 inch flange, ANSI
150

Min blanking

- Under ideal conditions 0.3m

INSTALLATION

Transmitter

The Transmitter is weather proof so it can be mounted outside. Although SUMPI is protected to IP65 it is recommended that it be installed inside another suitable enclosure.

The LCD display should not be facing full sunlight as this can cause the display to fail. SUMPI should be fixed to a wall or chassis plate using the four holes provided.

Do not install SUMPI in areas of high vibration as this may cause failure.

Do not install SUMPI in the close vicinity of electrical cable, SCR's or variable speed drives.

INSTALLATION

Transducer

The installation of the Transducer is the most important section of this manual and has been divided up into 7 sub sections.

1. The Transducer must be fitted at least 0.5m above the highest point of level.
2. Always use the plastic isolation kit. This kit must be fitted to a rigid support and must not be allowed to swing in a breeze. Use mild steel or a suitable plastic. Do not use stainless steel as this can cause ringing.

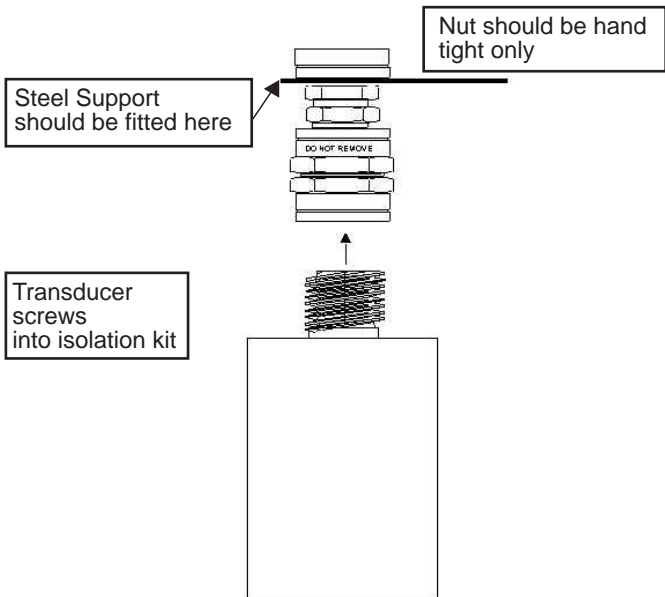

3. The Transducer must be perpendicular to the material it is measuring with a clear line of sight and must not be above beams or filling points.

Liquid level measurement.

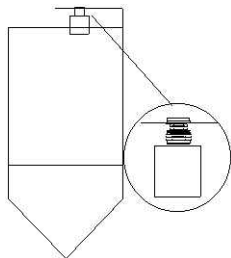

Transducer at 90 deg to surface.

Solid level measurement.

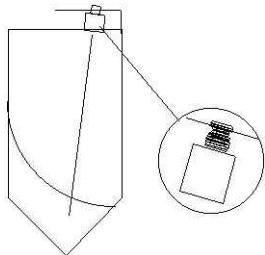

Transducer at 90 deg to surface.

4. If the Transducer is in a coned vessel, it must be positioned over the cone. This ensures that the Transducer receives the true echo and not one from the sides of the cone.

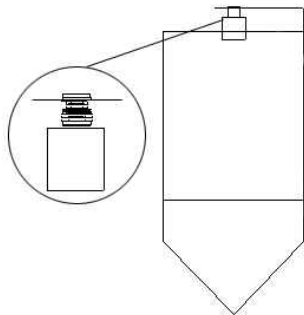

5. When a standpipe is being used it must be as wide as possible, i.e. the pipe diameter must be at least double its height and preferably be made of plastic. The base MUST have a 45° chamfer to reduce the echo size from the bottom of the standpipe. No welding should be present on the inside of the pipe as this causes false echoes.

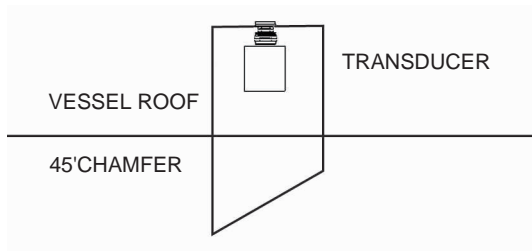

6. If any large electrical equipment is installed in the vicinity, then earthed steel conduit must be used.

7. An extension of up to 250m using RG62U cable is possible. All connections must be soldered together. It is advisable to install the Transducer cable inside steel conduit, especially if large electrical spikes (interference) are present.

INSTALLATION

Temperature Sensor

If there is a large change in temperature, a temperature sensor should be used. The error in level due to the change in temperature is 0.17% / deg'C. The Temperature sensor can be connected to the Transmitter via a 2 core overall screened cable.

Please note that the Temperature sensor is being used to measure the ambient air temperature and not the liquid temperature.

Do not mount the Temperature sensor in direct sunlight as this will increase the temperature reading.

KEY DESCRIPTION

SUMPI is "user friendly" having only 5 keys and a menu driven display .
The keys are listed below with their appropriate functions.

SCROLL

This is used to initially access the programming and then to run through the various menus.



This key is used to INCREASE value in the various commands.



This key is used to DECREASE value in the various commands.

ENTER

When the value has been selected it can be accepted by pressing the ENTER key.

RUN

When programming is complete, press RUN to return SUMPI back to the run mode.

SECURITY CODE

To advance to the programming mode the correct security code must be entered. The factory default code is 5159. The code can be changed in the programming mode.

CONFIGURATION

BASIC	OPTIONS	DEFAULTS	USER LIST
SECURITY CODE	0-9999	5159	
APPLICATION	LEVEL/DISTANCE	DISTANCE	
SET UP IN	METERS/FEET	METERS	
EMPTY DISTANCE	0.60-10.00	10.00	
SPAN	0.10-10.00	10.00	
BLANKING	0.30-10.00	0.50	
RATE OF CHANGE	0.10-10.00	1.00	
SET UP RELAYS	YES/NO	NO	
RELAY 1	OFF/HIGH/LOW	OFF	
RELAY 2	OFF/HIGH/LOW	OFF	
RELAY 1HIGH/LOW	0.0-10.00	0.0	
RELAY 1RESET	0.0-10.00	0.0	
RELAY 2HIGH/LOW	0.0-10.00	0.0	
RELAY 2RESET	0.0-10.00	0.0	
LIQUIDS/SOLIDS	LIQUIDS/SOLIDS	LIQUID	
DISPLAY MODE	M%/ENG UNITS	METERS	
ENG UNITS	AAA-ZZZ	AAA	
MULTIPLY FACTOR*	001-500	001	
DECIMAL POINT*	0.0000-00000.	000.00	
ECHO LOSS MODE	2/4/20/22mA/HOLD	HOLD	
ECHO LOSS TIME	30-900	300	
KABSCOPE ON TIME	1-10 HR	1 HR	
USE 21 PT LIN	YES/NO	NO	
FACTORY RESET	YES/NO	NO	
SET NEW PASSWORD	YES/NO	NO	
USE TEMP COMP	YES/NO	NO	

*PLEASE NOTE

MULTIPLY MODE AND DECIMAL POINT CAN ONLY BE SELECTED IF ENG. UNITS HAVE BEEN SELECTED.

SECURITY CODE

Security code to advance to programming.
DEFAULT 5159

APPLICATION

Choose between level and distance.
DEFAULT Distance

SET UP IN

Choose between meters and feet.
DEFAULT Meters

EMPTY DISTANCE

This is the distance from the face of the Transducer to the bottom of the tank.
DEFAULT 10.00m

SPAN

This figure is the measuring range of the instrument i.e. distance from the bottom of the tank to the highest point being measured. Remember, the material must not approach within 0.5 meters of the Transducer face.
DEFAULT 10.00m

BLANKING

This is the area where an echo cannot be processed because the return echo would be received whilst the Transducer is still firing.
DEFAULT 0.5m

RATE OF CHANGE

This is used to set up the rate of change of the level output. Increase the number if the level moves faster than 1 m / minute and decrease it if a more stable output is required.

DEFAULT 1m/min

SET UP RELAYS

The relays MUST be switched on here to set them up.

DEFAULT Off

RELAY 1

The relays can be used either for a high alarm or a low alarm. The difference is that a high alarm has its reset below the setpoint, and a low alarm has its reset above the setpoint.

DEFAULT Off

RELAY 2

As above.

DEFAULT Off

RELAY 1 HIGH or LOW depending upon selection

This is the setting for the High or the Low alarm depending on which was selected.

DEFAULT 0.00m

RELAY 1 RESET

This is where you can enter the reset. Please note that if it is a high alarm then the reset must be below and if it is a low alarm then the reset must be above the setting.

DEFAULT 0.00m

RELAY 2 HIGH or LOW depending upon selection

As above.

DEFAULT 0.00m

RELAY 2 RESET

As above.

DEFAULT 0.00m

LIQUIDS OR SOLIDS

This selection can be used to select either liquid or solid applications. The solid application will provide more power to locate the correct echo.

DEFAULT Liquids

DISPLAY

This prompt will allow you to display in meters, percentage or your own engineering units.

DEFAULT Meters

MULTIPLY FACTOR (only if Eng. units have been selected)

This prompt will allow you to display in a quantity rather than a distance such as 500. The display will be multiplied by this number, for example, 5 multiplied by 100 % would display 500 when full and 250 when at 50%.

DEFAULT 001

DECIMAL POINT (only if Eng. units have been selected)

This prompt will allow you to display with a decimal point.

DEFAULT 0000.0

ENG UNITS (only if Eng. units have been selected)

This prompt will allow you to display in your own engineering units and can be made up from alphanumeric characters. To select, press the up or down keys to get the first correct character, then press enter. Then repeat for the next character until all three characters are correct.

DEFAULT AAA

ECHO LOSS MODE

If a loss of echo condition is reached then the 4-20mA output will follow the configured settings 2mA, 4mA, 20mA, 22mA or hold the last recognised echo. This is usually due to a cable being cut or the above not being set up correctly.

DEFAULT Hold

ECHO LOSS TIME

This is the amount of time between last receiving a correct echo and going into the above Fail-safe condition. This time period is timed in seconds.

DEFAULT 300Sec

KABSCOPE ON TIME

This prompt will determine the length of time the SUMPI will communicate with KABScope. This time span is necessary as the instrument settings can be changed by mistake if the KABScope remains on.

DEFAULT 1 Hour

21 POINT LINEARISER

This prompt will allow you to input a curve to linearise the vessel. The span is divided by 21 and you can input the new height for each point. SUMPI prompts you at each point.

DEFAULT No

FACTORY RESET

This prompt will reset all values entered back to factory setting except the password. Please write down all settings before using this function.

DEFAULT No

SET NEW PASSWORD

This prompt will allow you to change the default factory code.

DEFAULT No

USE TEMPERATURE COMPENSATION

Select Yes only if a KAB10C or Temperature Transducer is connected.

DEFAULT No

EXAMPLES

Example 1

Distance measurement

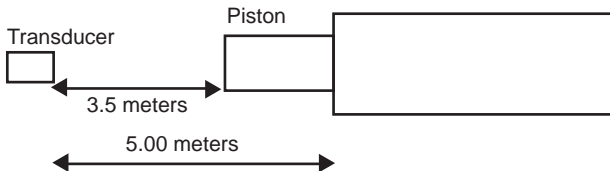

The above application deals with a moving piston:-

The maximum range for the piston is 5 m and the closest the piston can get to the Transducer is 0.5 m (Due to the blanking of the Transducer).

SECURITY CODE	5159
APPLICATION	DIST
FURTHEST DISTANCE	5.00m
RANGE	4.50m
BLANKING	0.5m
RATE OF CHANGE	1m/min

Below is what SUMPI will display on the above application.

Dist = 3.50m Relays DISABLED

The analogue output should be approximately 16.5 mA.

Example 2

Level measurement

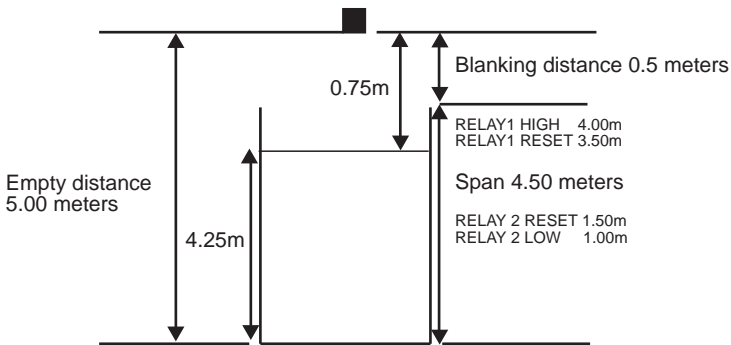

SECURITY CODE	5159
APPLICATION	LEVEL
EMPTY DISTANCE	5.00m
SPAN	4.50m
BLANKING	0.50m
RATE OF CHANGE	1m/min
SET UP RELAYS	YES
RELAY 1	HIGH
RELAY 2	LOW
RELAY 1 HIGH	4.00m
RELAY 1 RESET	3.50m
RELAY 2 LOW	1.00m
RELAY 2 RESET	1.50m

Below is what SUMPI will display on the above application.

Level 4.25m
Relay 1 On High

and

Level 4.25m
Relay 2 Off Low

Now the display will automatically toggle because both relays have been selected.

The analogue output should be approximately 19.1 mA.

Example 3

Level measurement with % and engineering units.

When the vessel is full it contains 4000 litres of water. The vessel will display 4000 when full and 2000 when half full. The level is at 82% in the example.

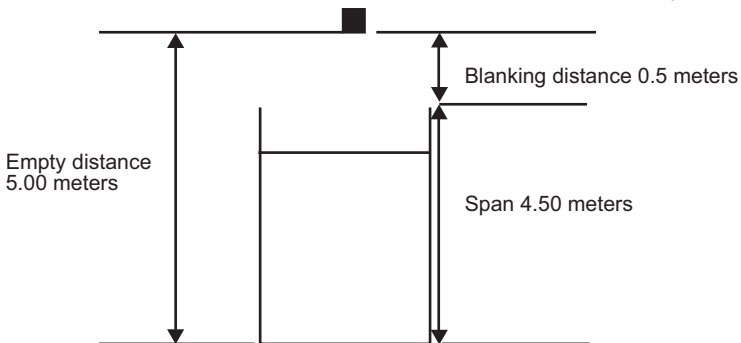

SECURITY CODE	5159
APPLICATION	LEVEL
EMPTY DISTANCE	5.00m
SPAN	4.50m
BLANKING	0.50m
DISPLAY MODE	Eng UNITS
MULTIPLY FACTOR	40
DECIMAL POINT	040.0
USER ENG. UNIT	LIT

Below is what SUMPI will display on the above application.

Level = 3280LIT Relays Disabled

The analogue output should be approximately 17.15 mA.

Example 4

Level measurement using the lineariser function.

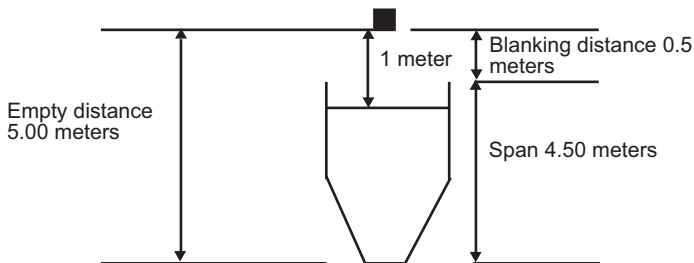

SECURITY CODE	5159
APPLICATION	LEVEL
EMPTY DISTANCE	5.00m
SPAN	4.50m
BLANKING	0.50m
DISPLAY	%
USE 21PT LIN	YES
0cm	0
22cm	1
45cm	2
67cm	3
90cm	5
112cm	8
135cm	10
157cm	12
180cm	15
202cm	17
225cm	21
247cm	25
270cm	29
292cm	35
315cm	45
337cm	50
360cm	60
382cm	70
405cm	80
427cm	90
450cm	100

Below is what SUMPI will display on the above application.

Level = 76.8 % Relays Disabled

The analogue output should be approximately 16.3 mA.

FAULT FINDING

There are three categories of possible faults. The malfunction of the instrument, loss of echo, and wrong reading.

The biggest problem is to identify the malfunction. If the instrument is not working satisfactorily then remove the transmitter and transducer to the workshop. Connect the power and the transducer directly, not using any extension cable. Aim the transducer to a wall about 2 meters away, making sure that it is perpendicular to the wall. Now reset the instrument by the factory reset prompt. The Instrument should now read Distance 2.00 m. If it does not read the above then there is a malfunction with the instrument and it should be returned for repair.

If the above works and it still does not work in the field then there are many possible problems. A list of possible problems follow:

Loss of echo.

Check all cable connections and solder the joints together.

Use only RG62U co-axial.

Check the specification of the transducers as agitated surfaces and solids do not reflect as powerful a signal as flat surfaces.

Aim the transducer straight down if used on liquids and perpendicular to the surface if used on solids.

Check if the Transducer face is dirty.

Wrong reading, always reading close to Transducer.

Check to see if the isolation kit has been used correctly and is only hand tight.

Do not reduce blanking distance below 0.5 m unless consultation has been made with KAB Instruments.

Electrical noise can cause this error. Remove noise.

Wrong reading, anywhere in tank.

Check to see if there is a reflection from the wall. Please note that a piece of wire across a tank can cause a big enough echo to be accepted.

Are the parameters correct? Reset to factory default and check that SUMPI reads correctly. If the factory settings are OK then your parameters need to be changed. Re-check these parameters with a tape measure.

Wrong reading, erratic.

Reduce Rate of Change. Not many levels move faster than 1 meter / minute.

Wrong reading, slow.

Increase Rate of Change.

TERMINAL CONNECTIONS

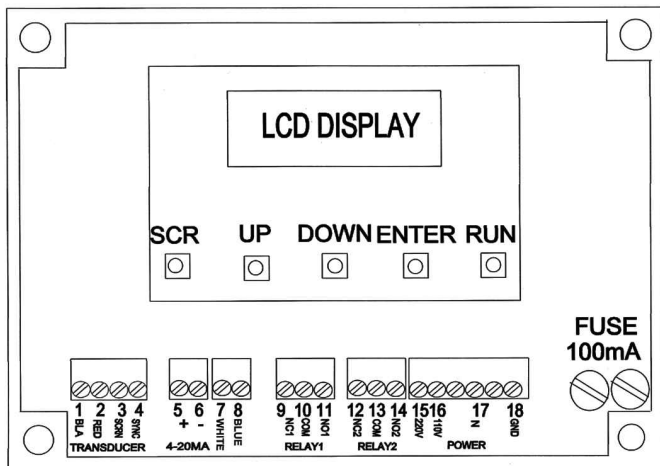

1. Transducer black
2. Transducer red
3. Transducer screen
4. Not used
5. 4-20mA output positive
6. 4-20mA output negative
7. Temperature probe white
8. Temperature probe blue
9. Relay 1 normally closed
10. Relay 1 common
11. Relay 1 normally open
12. Relay 2 normally closed
13. Relay 2 common
14. Relay 2 normally open
15. Power supply 220v live
16. Power supply 110v live
17. Power supply neutral
18. Ground

PLEASE NOTE FOR DC
OPERATION CONNECT
THE POWER TO
15. +24VDC
16. 0VDC

Please see page 36 if the
extension cable is used.

DIMENSIONS

Transmitter

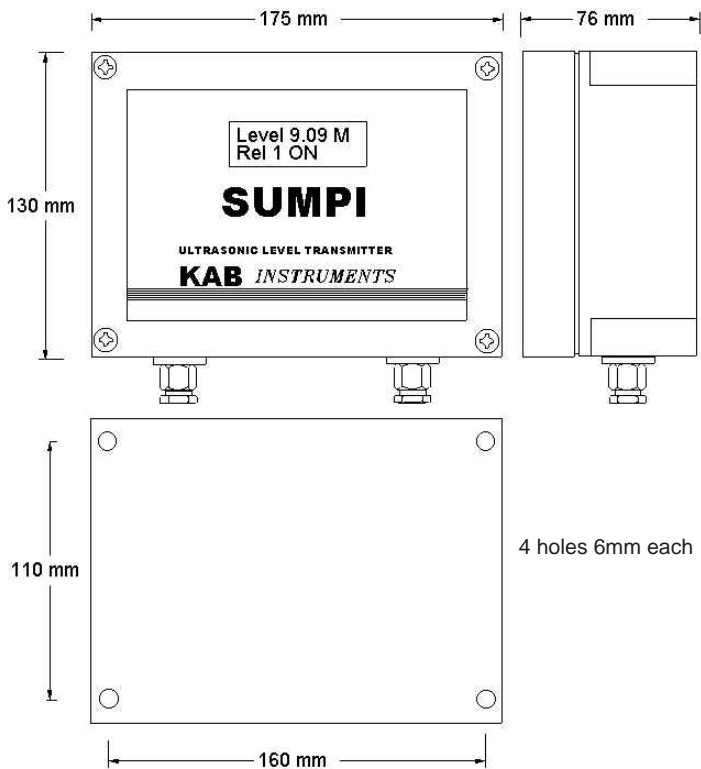

DIMENSIONS

Transducer KAB 10 / KAB 10C

Application, general use non-corrosive liquid.

KAB 10C has 2 extra wires. Blue and white for temperature compensation

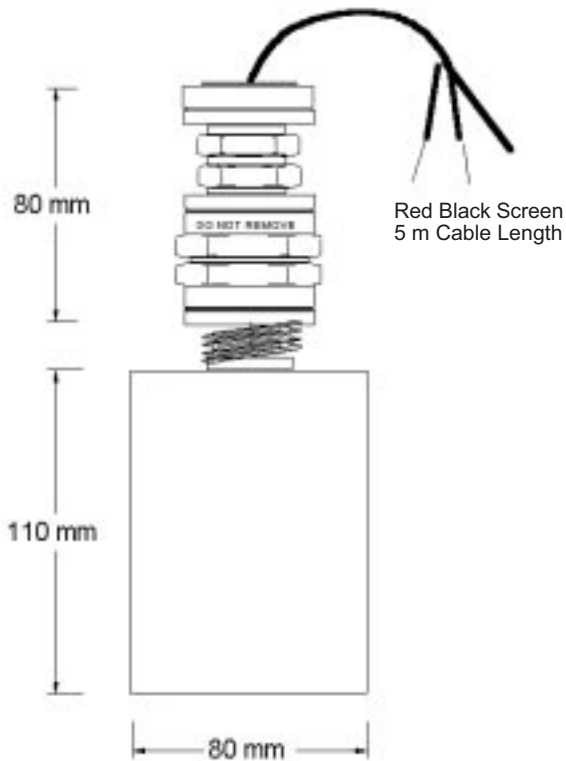

DIMENSIONS

Transducer KAB 10F

Application, solid or dusty environments.

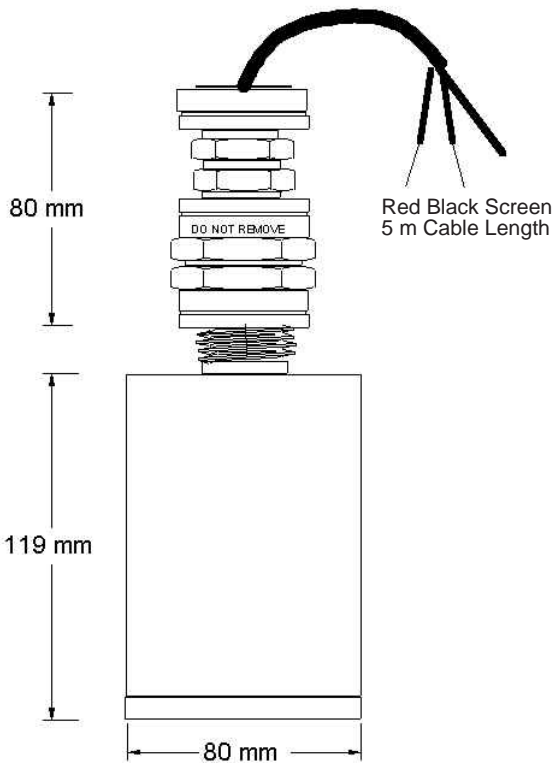

DIMENSIONS

Transducer KAB 10T (3 INCH)

Application, general use, non-corrosive liquids. Add PTFE for corrosive liquids

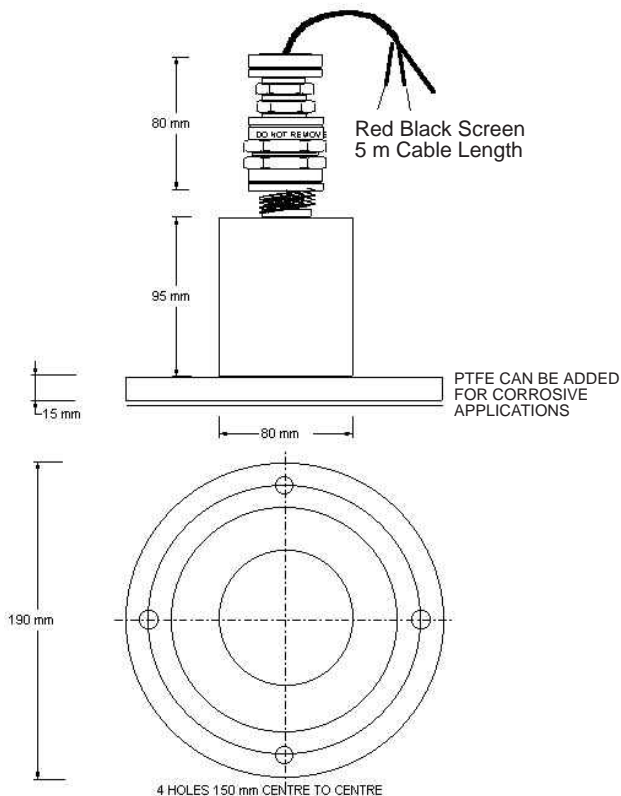

DIMENSIONS

Transducer KAB 10T (4 INCH)

Application, general use, non-corrosive liquids. Add PTFE for corrosive liquids.

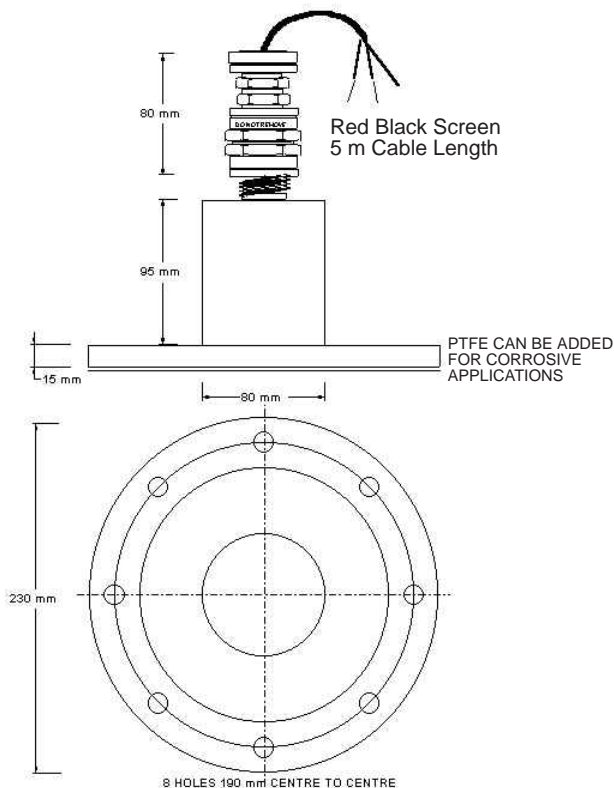

DIMENSIONS

Aiming kit

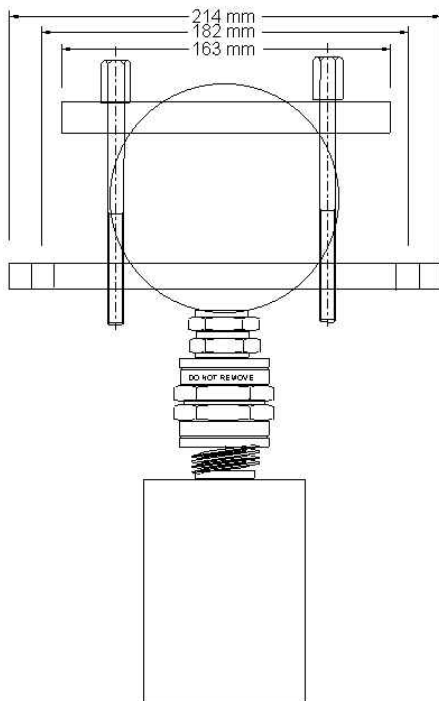

The four screws can be loosened so that the ball can move freely. You can then move the transducer for optimisation of the echo. The ball can then be tightened again with the four screws.

CABLE EXTENSION

Should it be necessary to extend the cable, KAB Instruments only recommend RG62U co-axial cable. The connection should be **SOLDERED** and connected as below.

The transducer cable to RG62U cable



The red cable from the transducer is soldered to the single conductor on the RG62U cable and the black and screen from the transducer are connected to the screen of the RG62U co-axial cable.

RG62U cable and input connection on the instrument



The other end of the RG62U cable should be connected to the transducer connection with the single conductor going to the red marked terminal and the screen going to the SCR marked terminal.

The extra length of cable should not exceed 250m. This distance could be shorter if the cable is run close to high voltage cables.

KABScope

KABScope is a software package designed by KAB Instruments to enable the user of KAB's range of SUMPI ultrasonic level instruments to enjoy rapid programming and fault finding when using the SUMPI range of products. Please note KABScope is not normally supplied with the SUMPI and must be purchased separately.

Background

The nature of ultrasonic level equipment dictates that an oscilloscope is needed to do fault finding on a level application. Most often the transducer is not mounted correctly and this can cause endless problems with even a simple application. Without an oscilloscope one would not necessarily determine this problem. Many technical personnel do not have access to an oscilloscope; hence the reason for the development of KABScope.

Operation

The KABScope is equipped with an on-screen oscilloscope which enables the user to conduct fault finding in the simplest manner. It also has a full programming menu that enables the user to set-up the unit on installation and to make any necessary changes to the unit.

The traditionally simple manner of programming the SUMPI range extends to the KABScope. Once the access code has been entered correctly the complete programming menu opens up into a Windows based display. All parameters can be altered in this window. The parameters of the SUMPI will be reflected on the display of the KABScope.

Set-up

The KABScope is simple to set-up. The following components are supplied.

- 1x CD-ROM containing KABScope software.
- 1x Comms Cable for communication between the SUMPI and desktop or laptop P.C.

Insert the CD-ROM into the P.C. and select KABScope from the menu and then D:/Setup. A prompt will appear once the installation is complete. KABScope has been successfully installed.

The next step is to connect the Comms cable from the P.C. to the SUMPI. For the connection to the P.C. the cable connects to one of the COM ports. This can be specified in the parameters of the KABScope under the CommPort/Port Properties menu.

SUMPI - the Comms cable has a junction box. The connector should be connected to the 4-pin header on the P.C. Board. The connector has locating ribs to ensure that it is installed correctly.

Once the installation is complete the following two steps should be followed to begin communication.

The CommPort menu should be opened to commence communication between the SUMPI and the P.C. The red icon can also be selected to open communications.

The "DOWN" button on the SUMPI must be depressed for approx. 3 seconds to begin communication between the SUMPI and the KABScope. The "DOWN" button can also be depressed to end the communication.

Other Features

In some cases, application problems can be extremely difficult to resolve. In situations like this KABScope can be used to save scope trends which can be emailed or faxed to KAB Instruments for possible solutions to the problematic application.