

PA03 Pulse Amplifier & CA03 Carrier Amplifier

Description

Economical signal conditioners by Flow Technology are designed for use with turbine flowmeters. The model CA03, when used with a modulated carrier (RF) pickoff, generates a carrier frequency which is modulated by the rotating blades of a turbine rotor. This eliminates the effects of magnetic drag, greatly extending the range and linearity of small meters at low flow rates. Exotic corrosion-resistant materials (e.g. Hastelloy C) typically impede signal output of magnetic and RF pickoffs. An enhanced version of the CA03 is selected for such applications.

The model PA03 conditions the output of a standard magnetic pickoff by converting the low level signal of the pickoff into clean pulse outputs.

Both signal conditioners may be used with a wide range of power supply voltages and produce output pulses proportional to the rotational rate of the turbine meter rotor. The output signals may be transmitted over wire lengths in excess of 1 mile (1.6 km).

Features

- Enhances turbine flowmeter performance
- Conditions modulated carrier or magnetic pickoffs
- Long range transmission (over 1 mile/1.6 km)
- 10 volts pulse output, frequency proportional to flow rate
- Remote mounted or integral with flowmeter
- Reverse voltage protected
- Lightweight polypropylene, NEMA 4X or explosion-proof enclosures
- DC-powered



CA03
Carrier Amplifier

Specifications

PA03

Input

Frequency Range	0 to 10 kHz
Impedance	Greater than 5 K ohms
Sensitivity	10 mV p-p @ 5 VDC power 20 mV p-p @ 30 VDC power

Output

Impedance	2.2 K ohms
Level	Pulse output 0–5 volts at 5 VDC power, 0 – 10 volts maximum

Power

5–32 VDC @ less than 30 mA

CA03

Input

Frequency Range	0.5–3500 Hz
Oscillator Frequency	45 kHz

Output

Impedance	10 ohms ±10%
Level	Pulse output 0–10 volts maximum

Power

22–32 VDC @ 30 mA
11–22 VDC @ 30 mA

PA03 & CA03

Temperature

Operating	-40° F to 185° F (-40° C to 85° C)
Storage	-67° F to 257° F (-55° C to 125° C)

Connections

Terminal Barrier Strip

Optional

Universal display mounted integral
(see Universal Display data
bulletin for specifications)

Model Numbering System

□ A 0 3 - □ - □ - 0 0 0 0 □ □

Basic Model No.

PA03 = Magnetic
CA03 = RF Carrier

Power Source

3 = 5-32 VDC (PA03)
3 = 22-32 VDC (CA03)
4 = 11-22 VDC (CA03)

Signal Input

A = Magnetic (PA03)
C = RF Carrier (CA03)
D = Other RF Carrier* (CA03)
E = Exotic Material RF Carrier (CA03)

Signal Output (no options)

0000 = 0-10 V p-p pluse

Enclosure Options

- 1 = No Enclosure
- 3 = Polypropylene
- 9 = Class I, Division 1, Group A, B, C, & D
- B6 = NEMA 4X with 1/2" Conduit Hubs
- B7 = NEMA 4X with MS Connectors
- BA = NEMA 4X with MS Connectors and Display
- BC = NEMA 4X with 1/2" Conduit Hubs and Display

Enclosure Options

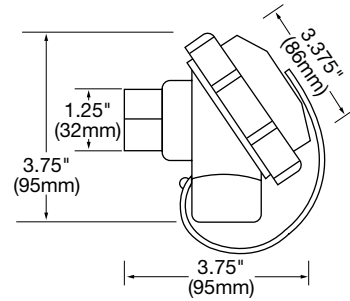

**3 = POLYPROPYLENE
(PA03 Only)**

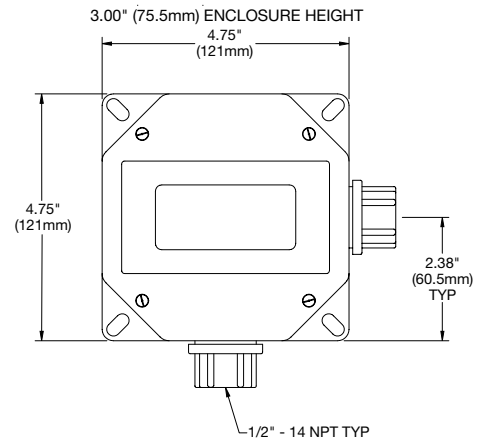

**B6 = NEMA 4X
(Shown with Universal Display)**

Wiring Diagram

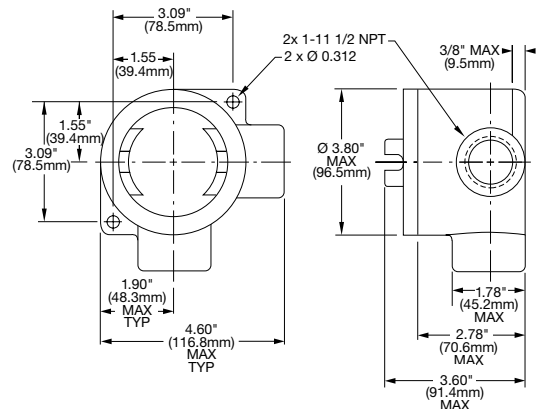
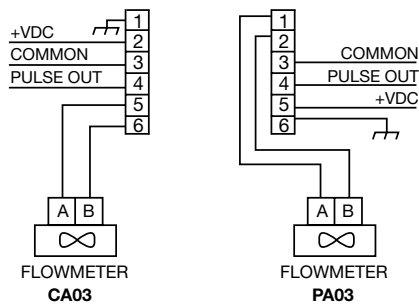

**9 = CLASS I, DIV. 1,
GROUPS A, B, C & D**

* For use with RF pickoffs that have 330 µH coils.

Specifications are for reference only and are subject to change without notice.

Local Representative:



4250 E. Broadway Road, Phoenix, Arizona 85040 USA
Tel: (602) 437-1315 • Fax: (602) 437-4459 • Toll Free: 1-800-528-4225
E-mail: ftimarket@ftimeters.com • Web: www.ftimeters.com

DB 62051 Rev E © 2000 FTI Flow Technology, Inc. Printed in USA