

SAFMAG β METER

ELECTROMAGNETIC FLOWMETER IN IRRIGATION WATER MEASUREMENT

South African Agriculture

is being driven to regulate the distribution of its scarce water resources.

The National Water Act 36 of 1998 has established Catchment Management Agencies (CMAs) and Water User Associations (WUAs) required to erect and maintain measuring devices in order to regulate the distribution of water from a water resource.

Stressed catchments require structured intervention to ensure the equitable distribution of available resources.

The Safmag β (Beta) Meter is designed for the South African water and irrigation industries. The Safmag β Meter is cost effective easy to use easy to install and provides excellent accuracy and reliable flow measurement in demanding environments.

The Safmag β Meter delivers exceptional accuracy of $\pm 0.5\%$ uses the long proven **non-intrusive** principle of electro-magnetic induction has no moving parts and introduces zero head loss. Readings are independent of density, temperature, viscosity and pressure. The β signal converter has state-of-the-art electronic components and a high-speed microprocessor for accuracy and reliability.

The Safmag is a South African designed and manufactured flow meter with a long history of delivering accurate and reliable flow measurement with exceptional local product support.

Water is becoming increasingly expensive. When you need to know how much how fast where and when the water went the β Meter is the natural choice. Flow total and flow rate are always available at the converter. Output signals available to remote instrumentation and telemetry include analogue digital outputs and RS485 capability.

Product features Safmag β Meter

Sensor size	DN 10..150 PN 16 IP67, IP68 (optional) W DN 150..600 PN 10/16 IP67, IP68 (optional) with MXI sensor
Transmitter	β remote wall mount IP65
Display	Two-line rate and total display
Configuration	Supplied to customers spec or modified on site via easy to use menu structure with touch keypad
Outputs	Configurable isolated pulse outputs, either 24Vdc active pulse or open collector pulse Isolated active 4-20mA programmable
Communication	RS485 enabled (optional)
Power supply	115Vac/230Vac 50Hz <5VA 80-240Vac 50/60Hz <5VA 12-30Vdc <5VA
Accuracy	+/- 0,5% of flow rate
Features	Low Cost Non-intrusive No pressure loss No moving parts No maintenance Active empty pipe detection Integral spike suppression Password and tamper protection Error displays for easy diagnostics Easy to install
Options	Integrated GSM telemetry Installation Kit Grounding rings (for lined or non-conductive pipe)

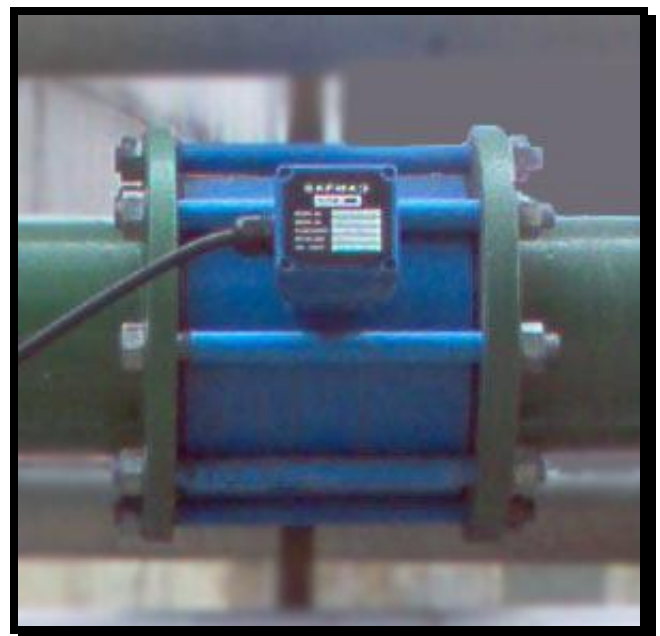

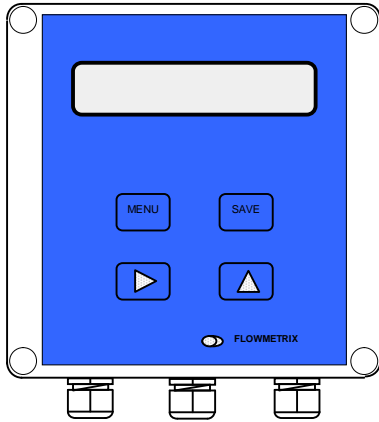

β Signal Converter 125(l) x 125(w) x 75(d)

W SENSOR DATA TABLE

Meter Size, ID (mm)	L1 (mm)	L2 (mm)	D1* (mm)	Mass (Kg)	Operating Flowrate m3/hr	
					Min**	Max
10	80	174	64	1.4	0.14	2.8
15	80	174	64	1.4	0.32	6.4
25	80	174	64	1.4	0.88	14
40	90	195	85	1.9	2.25	36
50	100	212	102	2.5	3.5	56
80	125	237	127	3.5	9	144
100	150	270	160	5.3	14.5	232
150	200	328	218	15	32.5	520

* D1 Fits between flange bolts for SABS 1123 1600, BS4505 PN16, BS10 T/D, ANSI 150#

** Minimum flowrate at which stated best accuracy applies

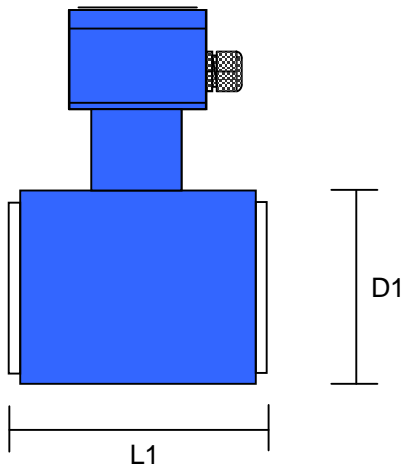

W SENSOR

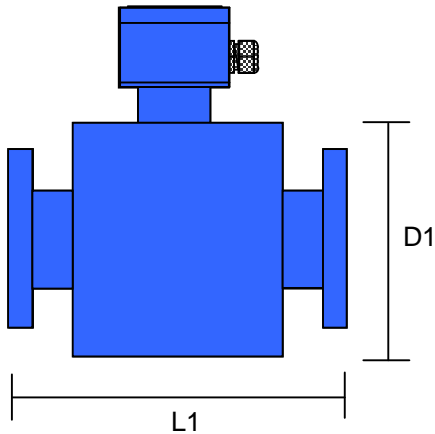
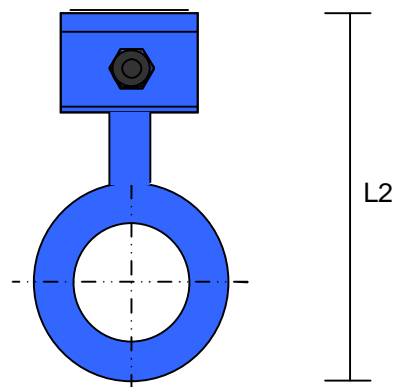

MXI SENSOR

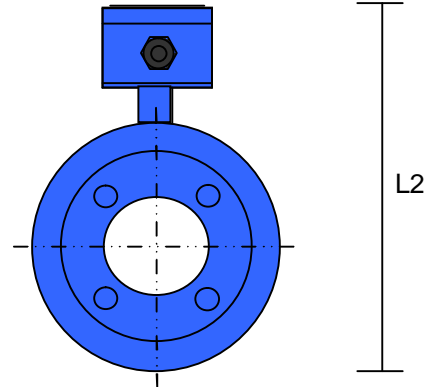

MXI SENSOR DATA TABLE

Meter Size, ID mm	L1 mm	L2 mm	D1 mm	Mass kg	Operating Flowrate m3/hr	
					Min**	Max
150	300	355	315	42	32	512
200	350	415	375	60	56	896
250	450	470	430	80	88	1408
300	500	525	485	100	127	2032
350	550	585	545	140	173	2768

** Minimum flowrate at which stated best accuracy applies

Meter Size, ID (mm)	L1 (mm)	L2 (mm)	D1 (mm)	Mass (Kg)	Operating Flowrate m3/hr	
					Min**	Max
400	600	645	605	190	226	3616
450	650	705	665	220	286	4576
500	700	775	735	280	354	5664
600	800	890	850	420	509	8144

SAFMAG β METER

ELECTROMAGNETIC FLOWMETER IN IRRIGATION WATER MEASUREMENT

SAMPLE	CODE	SAFMAG	150	D	2	HD	SS	R	010	W
SIZE										
010	10mm	DCMPU only								
015	15mm	DCMPU only								
025	25mm									
040	40mm									
050	50mm									
080	80mm									
100	100mm									
150	150mm									
200	200mm									
250	250mm									
300	300mm									
350	350mm									
400	400mm									
450	450mm									
500	500mm									
600	600mm									
SIGNAL CONVERTER										
B	BETA Converter									
D	DCMPU Converter									
SUPPLY VOLTAGE										
1	115Vac 50Hz									
2	230Vac 50Hz									
3	10-30Vdc									
4	80-240Vac 50/60Hz									
LINING MATERIAL										
PT	PTFE	-10 to 80°C								
HD	HDPE	-10 to 60°C								
NR	Natural rubber	-10 to 70°C								
ELECTRODE MATERIAL										
SS	316 Stainless steel									
CONVERTER MOUNTING										
R	Remote wall mount									
CABLE LENGTH										
010	Length in metres (max 100m)									
FLANGE PATTERN										
1	SABS 1123 1000/3 - 10 bar (MXI Sensor DN150..600)									
2	SABS 1123 1600/3 - 16 bar (MXI Sensor DN150..600)									
W	Wafer format – no flanges, 16 bar maximum (W Sensor DN25..150)									
		Fits between flange bolts for SABS 1123 1600, BS4505 PN16, BS10 T/D, ANSI 150#								